

As an alternative for reaching in, under, and around obstacles, Zimmerman Arm Systems allow an operator to precisely and effortlessly position loads regardless of physical strength.

Fitted with one of our standard or custom End Effectors, our Manipulator Arm Systems can perform a wide variety of material handling applications. Our full line of Arms offer the most flexibility available on the market today.



450 Arm shown with optional clamp end effector

## 400 Series Arms

Utilizing a parallel link design to maintain either end effector or tool orientation, these arms allow an operator to reach into an opening and manipulate a part or tool.

## 700 Series Arms

Consisting of a connecting linkage type boom that folds within itself to offer a large coverage area, these arms utilize the Balance Air® lifting and balancing unit as the lifting power.

## 600 Series Arms

Consist of a rigid vertical beam with a moving horizontal beam that is able to reach into an opening. These arms also utilize the Balance Air® for lifting and balancing power.

- Allows for reach in and off center applications.
- Variety of End Effector combinations.
- Can be adapted to most rail systems.



Self contained system with RAH, 720 arm, and 24 volt compressor integrated onto battery powered pallet truck. Integration to trucks, not performed by IR Zimmerman.



600 Arm shown with optional probe



700 C Arm (carriage mount) shown with optional end effector

# Arm Systems

## Series 700C



### Series 700C Arm

Part No.	Arm Length		Capacity		Weight	
	ft	m	lbs	kg	lbs	kg
70015@A**?++06#	6	1.83	150	65	218	99
70015@A**?++07#	7	2.13	150	65	237	108
70015@A**?++08#	8	2.44	150	65	248	113
70015@A**?++09#	9	2.74	150	65	263	120
70015@A**?++10#	10	3.05	150	65	275	125
70020@A**?++06#	6	1.83	200	90	248	113
70020@A**?++07#	7	2.13	200	90	267	121
70020@A**?++08#	8	2.44	200	90	278	126
70020@A**?++09#	9	2.74	200	90	278	126
70020@A**?++10#	10	3.05	200	90	304	138
70035@A**?++06#	6	1.83	350	155	257	117
70035@A**?++07#	7	2.13	350	155	279	127
70035@A**?++08#	8	2.44	350	155	290	132
70035@A**?++09#	9	2.74	350	155	290	132
70035@A**?++10#	10	3.05	350	155	316	144
70050@A**?++06#	6	1.83	500	225	271	123
70050@A**?++07#	7	2.13	500	225	290	132
70050@A**?++08#	8	2.44	500	225	328	149
70050@A**?++09#	9	2.74	500	225	350	159
70050@A**?++10#	10	3.05	500	225	367	167

### Series 700C Arm - Dimensions (inches)

Capacity (lbs)	Top mt										Bottom mt	
	A	B	C	D	G	J	K	H	L	H	L	
150	72	26	34	6.78	4.25	23.75	12	13.25	8	7.75	13.53	
150	84	38	34	6.78	4.25	23.75	12	13.25	8	7.75	13.53	
150	96	38	46	6.78	4.25	23.75	12	13.25	8	7.75	13.53	
150	108	38	46	6.78	4.25	23.75	24	13.25	8	7.75	13.53	
150	120	38	46	6.78	4.25	23.75	36	13.25	8	7.75	13.53	
200	72	26	34	6.78	4.25	26	12	13.25	11.13	7.75	13.66	
200	84	38	34	6.78	4.25	26	12	13.25	11.13	7.75	13.66	
200	96	38	46	6.78	4.25	26	12	13.25	11.13	7.75	13.66	
200	108	38	46	6.78	4.25	26	24	13.25	11.13	7.75	13.66	
200	120	38	46	6.78	4.25	26	36	13.25	11.13	7.75	13.66	
350	72	26	34	6.78	4.25	27	12	13.25	9.96	7.75	14.47	
350	84	38	34	6.78	4.25	27	12	13.25	9.96	7.75	14.47	
350	96	38	46	6.78	4.25	27	12	13.25	9.96	7.75	14.47	
350	108	38	46	6.78	4.25	27	24	13.25	9.96	7.75	14.47	
350	120	38	46	6.78	4.25	27	36	13.25	9.96	7.75	14.47	
500	72	26	34	6.78	4.25	27	12	13.25	10.63	7.75	14.16	
500	84	38	34	6.78	4.25	27	12	13.25	10.63	7.75	14.16	
500	96	38	46	8.5	5.5	27	12	13.25	11.38	7.75	16.63	
500	108	38	46	8.5	5.5	27	24	13.25	11.38	7.75	16.63	
500	120	38	46	8.5	5.5	27	36	13.25	11.38	7.75	16.63	

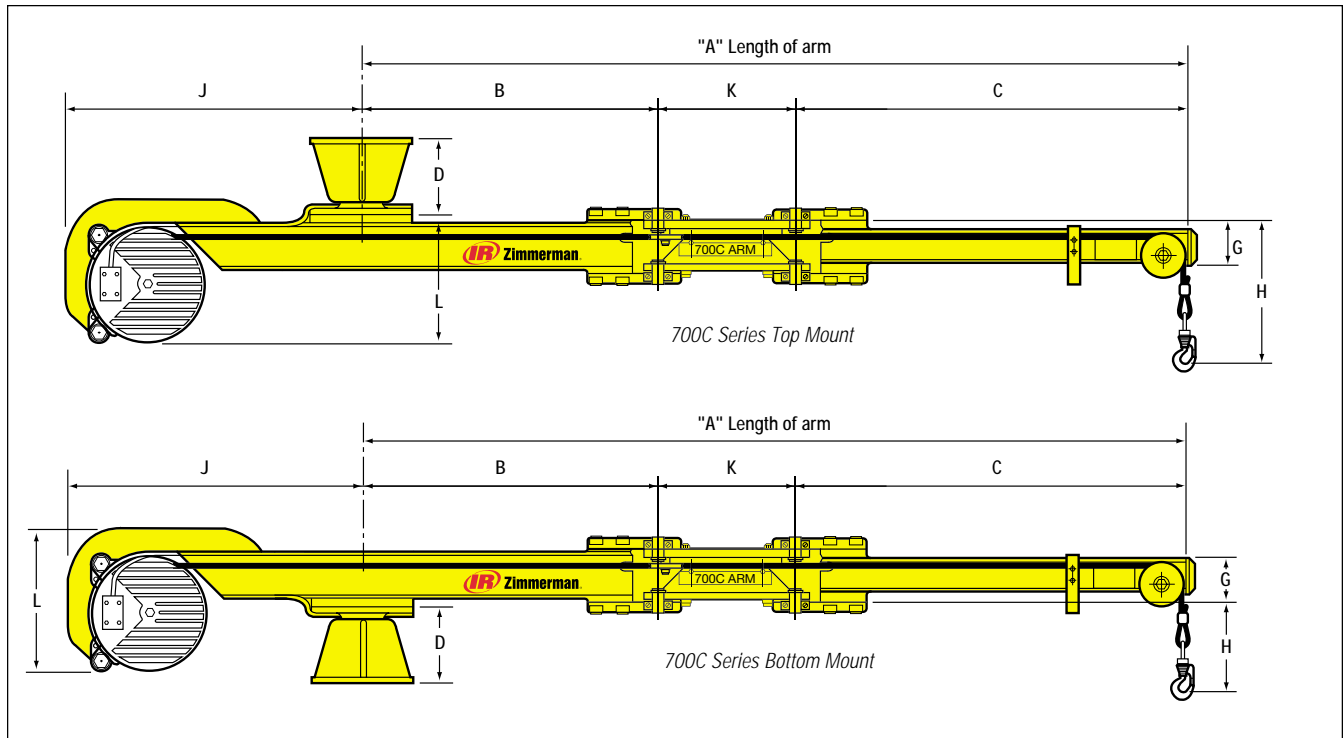

# Arm Systems

## Series 701C



Series 701C Arm						
Part No.	Arm Length		Capacity		Weight	
	ft	m	lbs	kg	lbs	kg
70115@A**?++06#	6	1.83	150	65	218	99
70115@A**?++07#	7	2.13	150	65	237	108
70115@A**?++08#	8	2.44	150	65	248	113
70115@A**?++09#	9	2.74	150	65	263	120
70115@A**?++10#	10	3.05	150	65	275	125

Series 701C Arm - Dimensions (inches)									
Capacity (lbs)	A	B	C	D	E	Top mt		Bottom mt	
						H	L	H	L
150	72	18	12	6.78	42	12.12	16.97	7.12	11.03
150	84	30	12	6.78	42	12.12	16.97	7.12	11.03
150	96	42	12	6.78	42	12.12	16.97	7.12	11.03
150	108	26	26	6.78	56	12.12	16.97	7.12	11.03
150	120	48	18	6.78	54	12.12	16.97	7.12	11.03

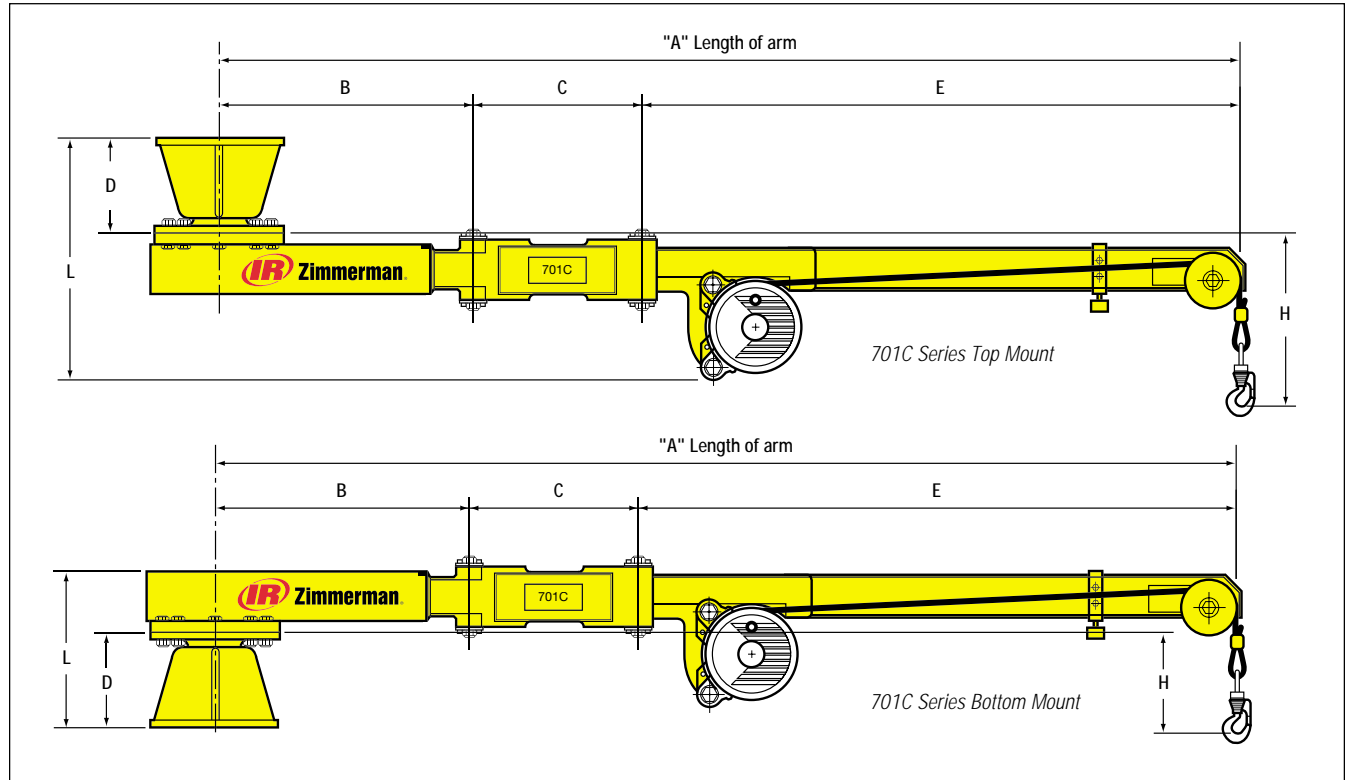

# Arm Systems

## Series 713



### Series 713 Arm

Part No.	Arm Length		Capacity		Weight	
	ft	m	lbs	kg	lbs	kg
71315@A**?+06#	6	1.83	150	65	151	69
71315@A**?+07#	7	2.13	150	65	166	75
71315@A**?+08#	8	2.44	150	65	175	80
71315@A**?+09#	9	2.74	150	65	184	84
71315@A**?+10#	10	3.05	150	65	228	104
71320@A**?+06#	6	1.83	200	90	197	90
71320@A**?+07#	7	2.13	200	90	213	97
71320@A**?+08#	8	2.44	200	90	224	102
71320@A**?+09#	9	2.74	200	90	235	107
71320@A**?+10#	10	3.05	200	90	281	128
71335@A**?+06#	6	1.83	350	155	233	106
71335@A**?+07#	7	2.13	350	155	246	112
71335@A**?+08#	8	2.44	350	155	261	119
71335@A**?+09#	9	2.74	350	155	258	117
71335@A**?+10#	10	3.05	350	155	271	123
71350@A**?+06#	6	1.83	500	225	261	119
71350@A**?+07#	7	2.13	500	225	275	125
71350@A**?+08#	8	2.44	500	225	276	125
71350@A**?+09#	9	2.74	500	225	335	152
71350@A**?+10#	10	3.05	500	225	351	160

### Series 713 Arm - Dimensions (inches)

Capacity (lbs)	Top mt								Bottom mt			
	A	B	C	D	F	G	H	E	K	E	K	L
150	72	41	31	6.78	9.19	3	10	5.46	3	4.75	8.5	11.53
150	84	47	37	6.78	9.19	3	10	5.46	3	4.75	8.5	11.53
150	96	53	43	6.78	9.19	3	10	5.46	3	4.75	8.5	11.53
150	108	59	49	6.78	9.19	3	10	5.46	3	4.75	8.5	11.53
150	120	65	55	6.78	9.19	3	10	5.46	3	4.75	8.5	11.53
200	72	41	31	6.78	12.81	4	9	5.46	3	4.75	8.5	11.53
200	84	47	37	6.78	12.81	4	9	5.46	3	4.75	8.5	11.53
200	96	53	43	6.78	12.81	4	9	5.46	3	4.75	8.5	11.53
200	108	59	49	6.78	12.81	4	9	5.46	3	4.75	8.5	11.53
200	120	65	55	6.78	12.81	4	9	5.46	3	4.75	8.5	11.53
350	72	41	31	6.78	12.81	4	9	5.54	3	4.75	8.5	11.53
350	84	47	37	6.78	12.81	4	9	5.54	3	4.75	8.5	11.53
350	96	53	43	6.78	12.81	4	9	5.54	3	4.75	8.5	11.53
350	108	59	49	6.78	12.81	4	9	6.78	3	6	8.5	12.78
350	120	65	55	6.78	12.81	4	9	6.78	3	6	8.5	12.78
500	72	41	31	6.78	12.81	4	9	5.54	3	4.75	8.5	11.53
500	84	47	37	6.78	12.81	4	9	5.54	3	4.75	8.5	11.53
500	96	53	43	8.5	12.81	4	9	6.79	3	6	8.5	14.5
500	108	59	49	8.5	12.81	4	9	6.79	3	6	8.5	14.5
500	120	65	55	8.5	12.81	4	9	6.79	3	6	8.5	14.5

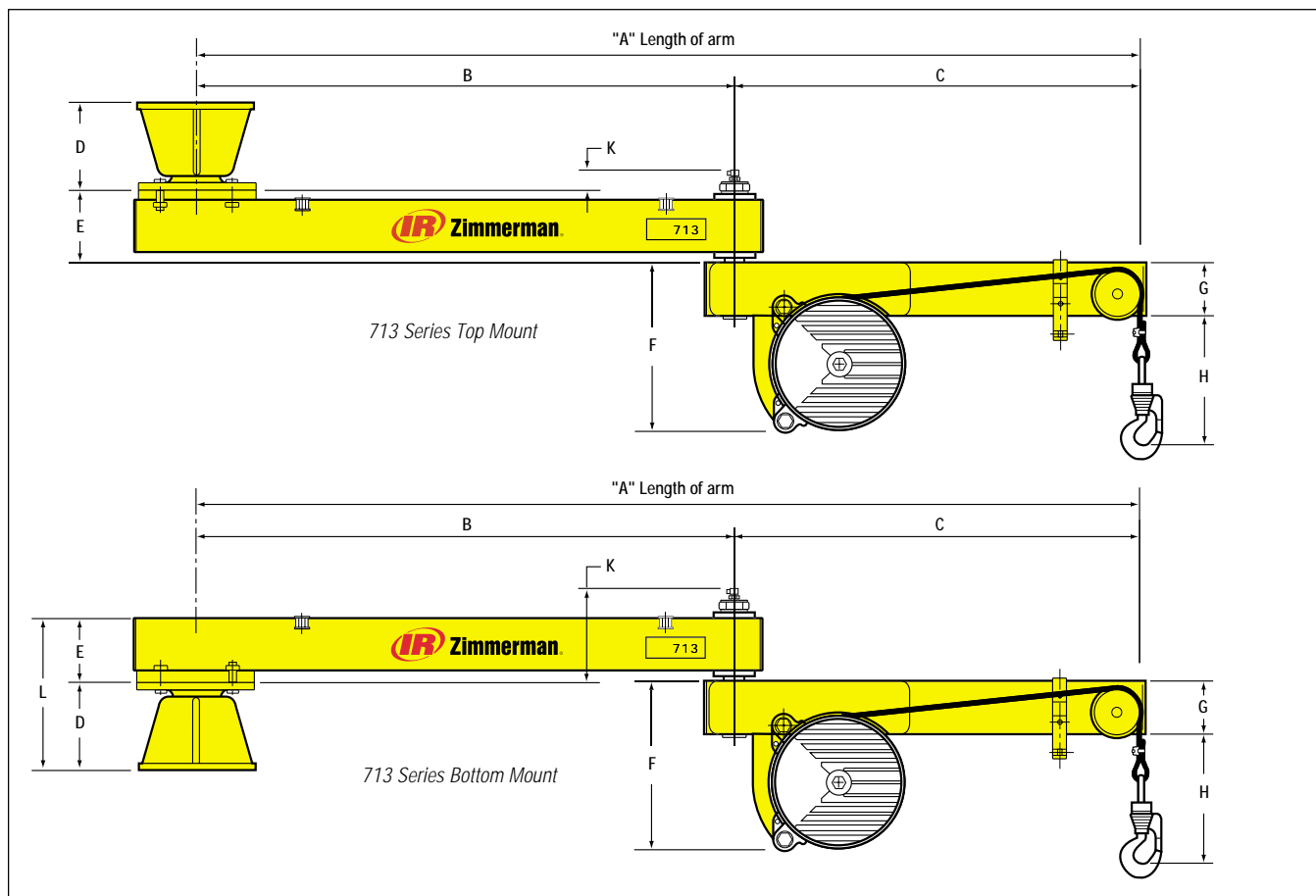

# Arm Systems

## Series 720



Series 720 Arm						
Part No.	Arm Length		Capacity		Weight	
	ft	m	lbs	kg	lbs	kg
72015@A**?++06#	6	1.83	150	65	218	99
72015@A**?++07#	7	2.13	150	65	237	108
72015@A**?++08#	8	2.44	150	65	248	113
72015@A**?++09#	9	2.74	150	65	263	120
72015@A**?++10#	10	3.05	150	65	275	125

Series 720 Arm - Dimensions (inches)										
Capacity (lbs)	Top mt									Bottom mt
	A	B	C	D	F	G	H	L	E	
150	72	41	31	6.78	7.8	3	16.5	11.53	5.46	4.75
150	84	47	37	6.78	7.8	3	16.5	11.53	5.46	4.75
150	96	53	43	6.78	7.8	3	16.5	11.53	5.46	4.75
150	108	59	49	6.78	7.8	3	16.5	11.53	5.46	4.75
150	120	65	55	6.78	7.8	3	16.5	11.53	5.46	4.75

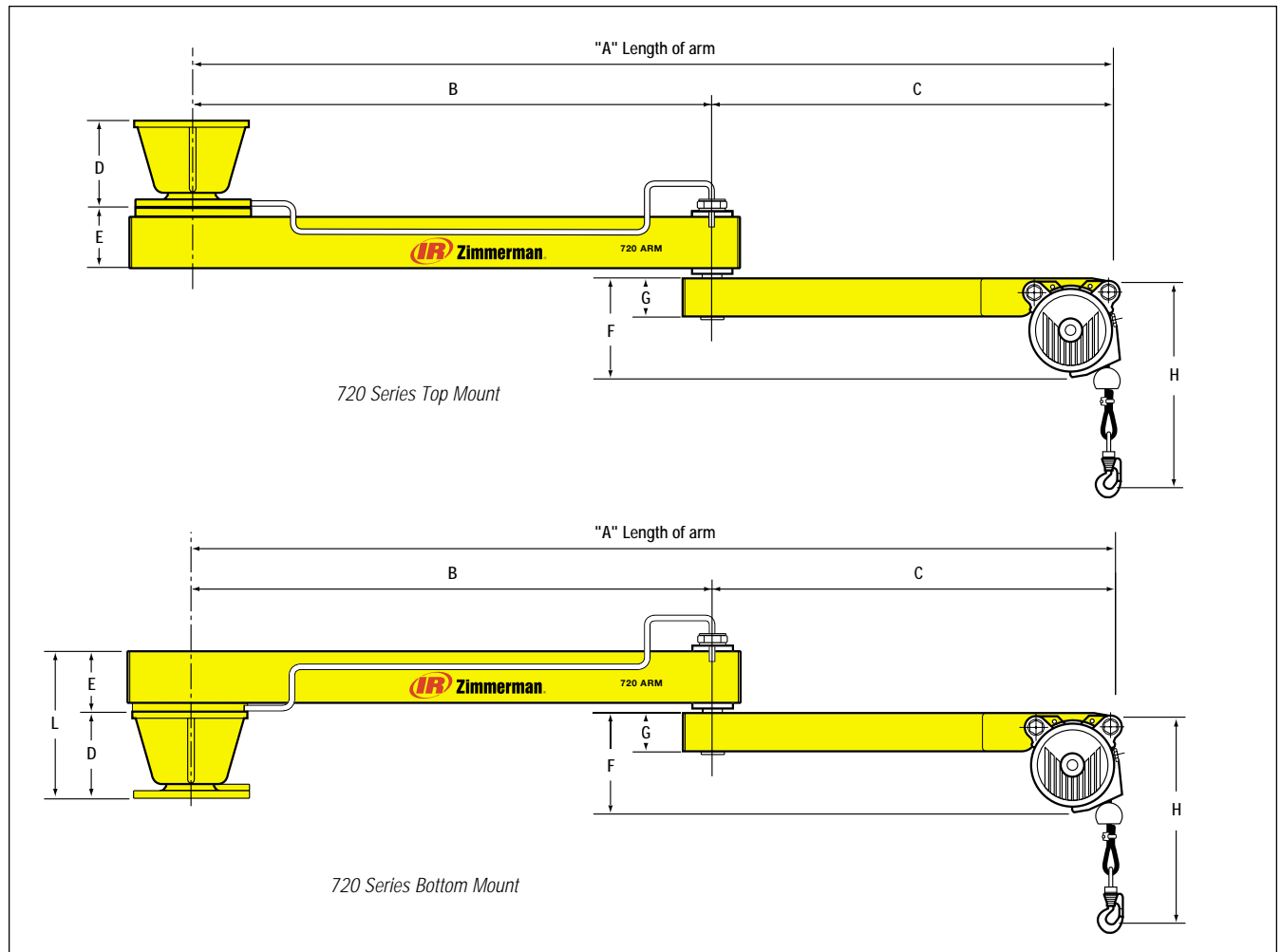

### 700 Arm Column Selection Chart

	Column Height in Feet (inches)					
	8' (96")	8' 6" (102")	9' (108")	10' (120")	11' (132")	12' (144")
<b>150 lb Balancer</b>						
6 ft Arm	54039110	54039128	54039136	54039144	54039151	54039169
7 ft Arm	54039110	54039128	54039136	54039144	54039151	54039169
8 ft Arm	54039110	54039128	54039136	54039144	54039151	54039169
9 ft Arm	54039110	54039128	54039136	54039144	54039151	54039169
10 ft Arm	54039110	54039128	54039136	54039144	54039151	54039169
<b>200 lb Balancer</b>						
6 ft Arm	54039110	54039128	54039136	54039144	54039151	54039169
7 ft Arm	54039110	54039128	54039136	54039144	54039151	54039169
8 ft Arm	54039110	54039128	54039136	54039144	54039151	54039169
9 ft Arm	54039110	54039128	54039136	54039144	54039219	54039227
10 ft Arm	54039110	54039128	54039136	54039201	54039219	54039227
<b>350 lb Balancer</b>						
6 ft Arm	54039110	54039128	54039136	54039201	54039219	54039227
7 ft Arm	54039177	54039185	54039193	54039201	54039219	54039227
8 ft Arm	54039177	54039185	54039193	54039201	54039219	54039227
9 ft Arm	54039177	54039185	54039193	54039201	54039219	54039227
10 ft Arm	54039177	54039185	54039193	54039201	54039219	54039227
<b>500 lb Balancer</b>						
6 ft Arm	54039177	54039185	54039193	54039201	54039219	54039227
7 ft Arm	54039177	54039185	54039193	54039201	54039219	54039227
8 ft Arm	54039235	54039243	54039250	54039268	54039276	54039284
9 ft Arm	54039235	54039243	54039250	54039268	54039276	54039284
10 ft Arm	54039235	54039243	54039250	54039268	54039276	54039284

**Note:**  
Use the Chart above to determine the Standard Column part number for your 700 Arm.

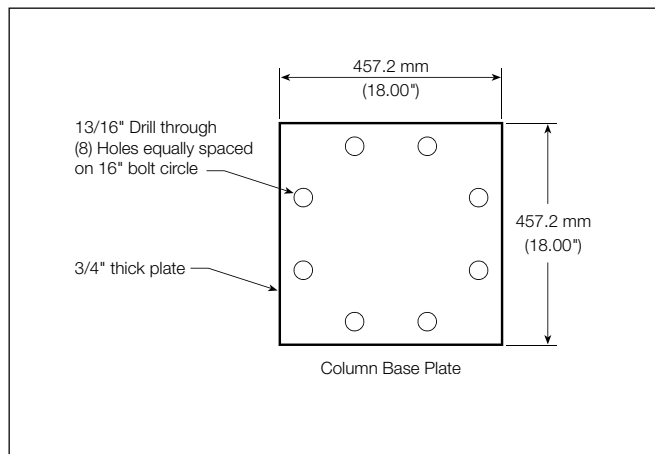

### Accessories (#)

#	Description
A	Overhead Mount Column 13.12 inches tall (for use with ceiling mounted arms)
B	Column, 8 feet tall
C	Column, 8 feet 6 inches tall
D	Column, 9 feet tall
E	Column, 10 feet tall
F	Column, 11 feet tall
G	Column, 12 feet tall

**Note:**  
Refer to 700 Arm Column Selection Chart for sizing data and part numbers.

### Carriages (\*\*)

**	Description	Part No.
NT	Carriage-Basic, no trolleys	40710
TR	Carriage Assembly - T-Rail / I-Beam	40709
A2	Carriage Assembly - ZRA2 (reaction trolley)	30028-1
S2	Carriage Assembly - ZRS2 / ZRS3	30028-2
A1	Carriage Assembly - ZRA1	30028-3
E8	Carriage Assembly - ETA-8 (reaction trolley)	30028-4
K2	Carriage Assembly - KBK2	30028-5

**Notes:**  
Lightweight ALMAG casting. Basic carriage weighs 60.0 lbs (27.3 kg)  
Each Carriage Ass'y drawing has info for both Hi & Low Profile Assemblies.

### Controls (++)

++	Description
ZP	ZA (Zim-Air) Pendant control
ZQ	ZA (Zim-Air) Quad-Coil
ZT	ZA (Zim-Air) Tri-Coil
BA	BA (Balance-Air) Standard
BZ	BA (Balance-Air) Z-Servo
EP	EA (Equi-Air) 2PS Pressure
EV	EA (Equi-Air) 2PS Vacuum

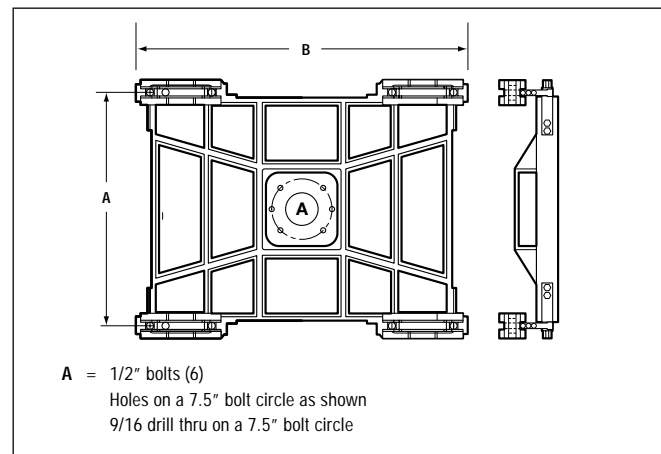

# How to Order



## Series 700 Arm

Example: 70015SATT0ZP06A

700 15 S A TT 0 ZP 06 A

**Style** \_\_\_\_\_

- 700
- 701 (150 lb capacity only)
- 713
- 720 (150 lb capacity only)

**Capacity** \_\_\_\_\_

- 15 = 150 lbs (68.2 kg) - 80 in. (2032 mm)
- 20 = 200 lbs (90.9 kg) - 120 in. (3048 mm)
- 35 = 350 lbs (159.1 kg) - 80 in. (2032 mm)
- 50 = 500 lbs (227.3 kg) - 80 in. (2032 mm)

**Intelift Options (@)** \_\_\_\_\_

- S = Standard Balancer
- I = Intelift Balancer (Consult factory)

**Arm** \_\_\_\_\_

**Mounting Options (\*\*)** \_\_\_\_\_

- TT = Top Mount (Celling mount)      S2 = ZRS2 Carriage Mount
- BB = Bottom Mount (Column mount)    TR = T-Rail Carriage Mount
- A1 = ZRA1 Carriage Mount\*            E8 = ETA-8 Carriage Mount
- A2 = ZRA2 Carriage Mount            K2 = KBK2 Carriage Mount

\*Note: A1 Carriage Mount Option is only available for arms with 150 and 200 lbs (65 and 90 kg) capacity / 6, 7, and 8 ft (1.83, 2.13 and 2.44 m) length.

**Carriage Options (?)** \_\_\_\_\_

- 0 = No Carriage
- H = High-Profile Carriage
- L = Low-Profile Carriage

**Controls (++)** \_\_\_\_\_

- ZP = ZA (Zim-Air) Pendent Control      EP = EA (Equi-Air) 2PS Pressure
- ZQ = ZA (Zim-Air) Quad-Coil            EV = EA (Equi-Air) 2PS Vacuum
- ZT = ZA (Zim-Air) Tri-Coil
- BA = BA (Balance-Air) Standard
- BZ = BA (Balance-Air) Z-Servo

**Arm Length** \_\_\_\_\_

- 06 = 6 ft (1.83 m) Arm
- 07 = 7 ft (2.13 m) Arm
- 08 = 8 ft (2.44 m) Arm
- 09 = 9 ft (2.74 m) Arm
- 10 = 10 ft (3.05 m) Arm

**Mounating Accessories (#)** \_\_\_\_\_

- 0 = No Mounting Accessories            D = 9 ft (2.74 m) Column Mount
- A = 13 in. (0.33 m) Ceiling Mount      E = 10 ft (3.05 m) Column Mount
- B = 8 ft (2.44 m) Column Mount        F = 11 ft (3.35 m) Column Mount
- C = 8 ft 6 in. (2.59 m) Column Mount    G = 12 ft (3.66 m) Column Mount

# Arm Systems

## Series 600 Arm



### Series 600 Arm - Allowable Mast Configurations

lbs	Load (L) max	Load CG (C) max		Single Mast Ht. (H) max		Max Hook Travel (V) <sup>(1)</sup>	
	kg	in	mm	in	mm	in	mm
<b>Single Mast Configuration</b>							
150	68.2	12	305	144	3658	80	2032
		24	610	144	3658	80	2032
		36	914	144	3658	80	2032
		48	1219	144	3658	80	2032
		60	1524	138	3505	80	2032
200	90.9	72	1829	114	2896	74	1880
		12	305	144	3658	104	2642
		24	610	144	3658	104	2642
		36	914	144	3658	104	2642
		48	1219	126	3200	86	2184
350	159.1	60	1524	102	2591	62	1575
		72	1829	84	2134	44	1118
		12	305	144	3658	80	2032
		24	610	144	3658	80	2032
		36	914	96	2438	56	1422
500	227.3	48	1219	72	1829	32	813
		60	1524	60	1524	20	508
		72	1829	48	1219	8	203
		12	305	144	3658	80	2032
		24	610	102	2591	62	1575
700	318.2	36	914	66	1676	26	660
		48	1219	54	1372	14	356
		12	305	138	3505	40/80	1016/2032
		24	610	72	1829	26/32	660/813
		36	914	48	1219	2/8	51/203
1000	454.5	12	305	96	2438	40/56	1016/1422
		24	610	54	1372	8/14	203/356
<b>Dual Mast Configuration</b>							
150	68.2	60	1524	144	3658	80	2032
		72	1829	144	3658	80	2032
200	90.9	48	1219	144	3658	104	2642
		60	1524	144	3658	104	2642
350	159.1	72	1829	144	3658	104	2642
		36	914	144	3658	80	2032
		48	1219	144	3658	80	2032
500	227.3	60	1524	120	3048	80	2032
		72	1829	102	2591	62	1575
		24	610	144	3658	80	2032
700	318.2	36	914	144	3658	80	2032
		48	1219	144	3658	80	2032
		12	305	144	3658	40/80	1016/2032
1000	454.5	24	610	144	3658	40/80	1016/2032
		36	914	102	2591	40/62	1016/1575
1000	454.5	12	305	144	3658	40/80	1016/2032
		24	610	108	2743	40/68	1016/1727



600 Arm shown with optional probe

### Series 600 Arm - Mast Configurations

Part No.	Capacity		Max. Travel		Notes
	lbs	kg	in	mm	
<b>Single Mast Configuration</b>					
60015@A1**+&#	150	68.2	80	2032	1x Balancer
60020@A1**+&#	200	90.9	120	3048	1x Balancer
60035@A1**+&#	350	159.1	80	2032	1x Balancer
60050@A1**+&#	500	227.3	80	2032	1x Balancer
6007R@A1**+&#	700	318.2	40	1016	1x Bal. (reeved)
6007T@A1**+&#	700	318.2	80	2032	2x Balancer
6001R@A1**+&#	1000	454.5	40	1016	1x Bal. (reeved)
6001T@A1**+&#	1000	454.5	80	2032	2x Balancer
<b>Dual Mast Configurations</b>					
60015@A2**+&#	150	68.2	80	2032	1x Balancer
60020@A2**+&#	200	90.9	120	3048	1x Balancer
60035@A2**+&#	350	159.1	80	2032	1x Balancer
60050@A2**+&#	500	227.3	80	2032	1x Balancer
6007R@A2**+&#	700	318.2	40	1016	1x Bal. (reeved)
6007T@A2**+&#	700	318.2	80	2032	2x Balancer
6001R@A2**+&#	1000	454.5	40	1016	1x Bal. (reeved)
6001T@A2**+&#	1000	454.5	80	2032	2x Balancer

# Arm Systems

## Series 600 Arm



### Vertical Travel of Balancer (Q) VS. Mast Height (H) - 32 in (812mm)

Balancer Capacity		Vertical Travel (Q)		Notes
lbs	kg	in	mm	
150	68.2	80	2032	1 x Balancer
200	90.9	120	3048	1 x Balancer
350	159.1	80	2032	1 x Balancer
500	227.3	80	2032	1 x Balancer
700 <sup>(1)</sup>	318.2	40	1016	1 x Balancer (reeved)
700 <sup>(2)</sup>	318.2	80	2032	2 x Balancer
1000 <sup>(1)</sup>	454.5	40	1016	1 x Balancer (reeved)
1000 <sup>(2)</sup>	454.5	80	2032	2 x Balancer

**Notes:**

- (1) = 1 Balancers Reeved
- (2) = 2 Balancers Tandem

### Series 600 Arm - Mast Configurations

Part No.	Arm Sub-Assy No.	Balancer Part No.
<b>Single Mast Configuration</b>		
60015@A1**+&#	54039649	BW015080000
60020@A1**+&#	54039664	BW020120S00
60035@A1**+&#	54039664	BW035080S00
60050@A1**+&#	54039664	BW050080S00
6007R@A1**+&#	54039664	BW070040S00
6007T@A1**+&#	54039680	BW070080S00
6001R@A1**+&#	54039664	BW100040S00
6001T@A1**+&#	54039680	BW100080S00
<b>Dual Mast Configuration</b>		
60015@A2**+&#	54039656	BW015080000
60020@A2**+&#	54039672	BW020120S00
60035@A2**+&#	54039672	BW035080S00
60050@A2**+&#	54039672	BW050080S00
6007R@A2**+&#	54039672	BW070040S00
6007T@A2**+&#	54039698	BW070080S00
6001R@A2**+&#	54039672	BW100040S00
6001T@A2**+&#	54039698	BW100080S00

### Carriages (\*\*)

**	Description	Stack-up <sup>(1)</sup> (CS)	Part No.
NT	Carriage-Basic, no trolleys		40710
TR	Carriage - T-Rail / I-Beam	5.46	40709
A2	Carriage - ZRA2 (reaction trolley)	5.97	30028-1
S2	Carriage - ZRS2 / ZRS3	5.97	30028-2
A1	Carriage - ZRA1	8.44	30028-3
E8	Carriage - ETA-8 (reaction trolley)	7.16	30028-4
K2	Carriage - KBK2	5.97	30028-5

**Note:**

- Lightweight ALMAG casting. Carriage weighs 60.0 lbs (27.3 kg)
- (1) Dimension is from the rail running surface to the base of the pivot. Changes with brake option.

### Controls (+)

+	Description	Controls Sub-Assembly No.	
		1x Mast	2x Mast
Z	ZA (Zim-Air) Control	54039847	54039854

### Brake Options (&)

&	Description	Part No.
0	No brake	-
P	Pin-lock Brake (hard stops every 45 degrees)	54039722
B	Bumper Friction Brake	54039730
C	Caliper Brake	54040977

### Masts (#)

#	Description	Part No.
A	ZRA2 Mast, 4' [1.22 m] Long	30000-040-2
B	ZRA2 Mast, 4' 6" [1.37 m] Long	30000-045-2
C	ZRA2 Mast, 5' [1.52 m] Long	30000-050-2
D	ZRA2 Mast, 5' 6" [1.68 m] Long	30000-055-2
E	ZRA2 Mast, 6' [1.83 m] Long	30000-060-2
F	ZRA2 Mast, 6' 6" [1.98 m] Long	30000-065-2
G	ZRA2 Mast, 7' [2.13 m] Long	30000-070-2
H	ZRA2 Mast, 7' 6" [2.29 m] Long	30000-075-2
J	ZRA2 Mast, 8' [2.44 m] Long	30000-080-2
K	ZRA2 Mast, 8' 6" [2.59 m] Long	30000-085-2
M	ZRA2 Mast, 9' [2.74 m] Long	30000-090-2
N	ZRA2 Mast, 9' 6" [2.90 m] Long	30000-095-2
P	ZRA2 Mast, 10' [3.05 m] Long	30000-100-2
Q	ZRA2 Mast, 10' 6" [3.20 m] Long	30000-105-2
R	ZRA2 Mast, 11' [3.35 m] Long	30000-110-2
S	ZRA2 Mast, 11' 6" [3.51 m] Long	30000-115-2
T	ZRA2 Mast, 12' [3.66 m] Long	30000-120-2

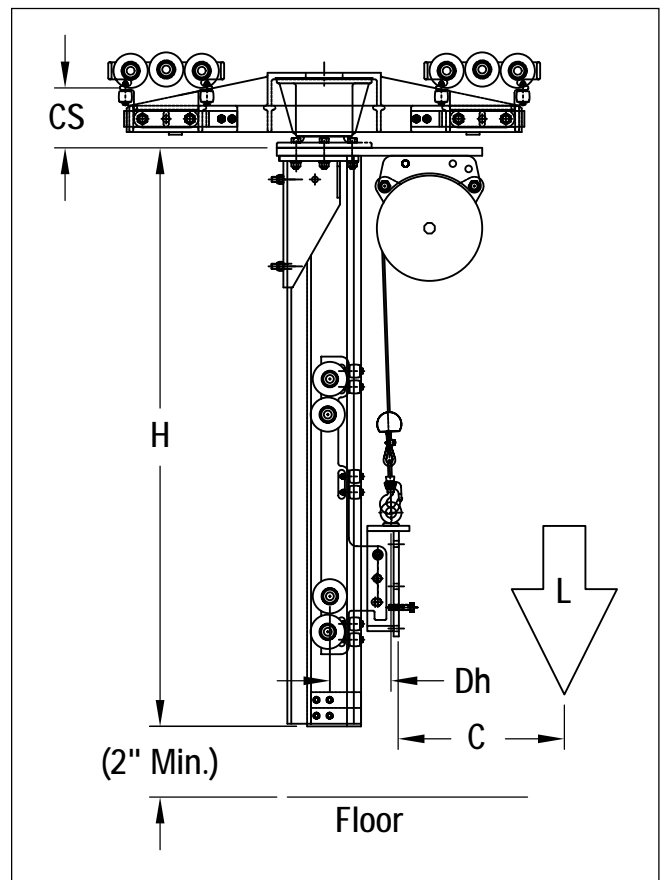

# How to Order



## Series 600 Arms

Example: 60015IA1A2ZPG

600 15 I A 1 A2 Z P G

Style \_\_\_\_\_

600

Capacity - Vertical Travel \_\_\_\_\_

- 15 = 150 lbs (68.2 kg) - 80 in. (2032 mm)
- 20 = 200 lbs (90.9 kg) - 120 in. (3048 mm)
- 35 = 350 lbs (159.1 kg) - 80 in. (2032 mm)
- 50 = 500 lbs (227.3 kg) - 80 in. (2032 mm)
- 7R = 700 lbs (318.2 kg) - 40 in. (1016 mm)
- 7T = 700 lbs (318.2 kg) - 80 in. (2032 mm)
- 1R = 1000 lbs (454.5 kg) - 40 in. (1016 mm)
- 1T = 1000 lbs (454.5 kg) - 80 in. (2032 mm)

Intelift Options (@) \_\_\_\_\_

- S = Standard Balancer
- I = Intelift Balancer (Consult factory)

Arm \_\_\_\_\_

Single or Dual Mast \_\_\_\_\_

- 1 = Single Mast
- 2 = Dual Mast

Carriage Options (\*\*\*) \_\_\_\_\_

- A1 = ZRA1
- A2 = ZRA2
- S2 = ZRS2
- S3 = ZRS3
- TR = T-Rail
- E8 = ETA-8
- K2 = KBK2

Note: All Zimmerman 600 Arms use a Low Profile Carriage Assembly

Controls (+) \_\_\_\_\_

- Z = ZA (Zim-Air) Control (Includes dummy handle)

Brake Options (&) \_\_\_\_\_

- O = No brake
- P = Pin-lock Brake (hard stops every 45 degrees)
- B = Bumper Friction Brake (soft stop at any point on 360 degree rotation)
- C = Caliper Brake

Mast Length (#) \_\_\_\_\_

- |                         |                         |                          |
|-------------------------|-------------------------|--------------------------|
| A = 4 ft (1.22 m)       | G = 7 ft (2.13 m)       | P = 10 ft (3.05 m)       |
| B = 4 ft 6 in. (1.37 m) | H = 7 ft 6 in. (2.29 m) | Q = 10 ft 6 in. (3.20 m) |
| C = 5 ft (1.52 m)       | J = 8 ft (2.44 m)       | R = 11 ft (3.35 m)       |
| D = 5 ft 6 in. (1.68 m) | K = 8 ft 6 in. (2.59 m) | S = 11 ft 6 in. (3.51 m) |
| E = 6 ft (1.83 m)       | M = 9 ft (2.59 m)       | T = 12 ft (3.66 m)       |
| F = 6 ft 6 in. (1.98 m) | N = 9 ft 6 in. (2.90 m) |                          |