

AIR BLOW GUNS

Ideal for Blowing Dusts and Dry it out.

Features

- ① Large enough holder for easy hanging
- ② 14 different nozzle guns
- ③ Four finger throttle lever for less fatigue. And easy grip and non-slip with ergonomic handle for efficient operation.
- ④ There are designed with polyacetal plastics for its oil resistance, anti-worn-out characters different from regular metal housing.

※ No nozzle replacement so that it does not slip away during work for safety.

Applicable for Dusting Metal, Wood Cut-off Articles and Drying Wet Paint

Applications

Air blowing and drying for metal forming, automobile repair, molding milling, etc.



Soft Rubber Adapter for Safety Blowing

Nozzle with soft rubber tip



Rubber Tip Nozzle
AD-2 OR

Rubber Tip Long Nozzle
AD-2 100R

Safety, Calm and Soft Blowing

Widely spreads air safe and quiet



Safety By-Pass Nozzle
AD-2 OS

Safety By-Pass Long Nozzle
AD-2 100S

Standard Nozzle
AD-2 ON



AD-2 ON-PB

Long Nozzle
AD-2 100N



AD-2 100N-PB

Long Nozzle



AD-2 300N

25° Degree Long Nozzle

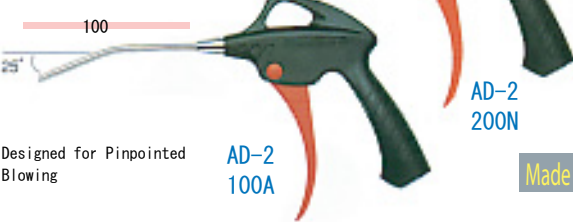

AD-2 100A

Designed for Pinpointed Blowing

Made Plate Prevents Dust and Deburings Flying

Chip Shield Long Nozzle
AD-2 100P

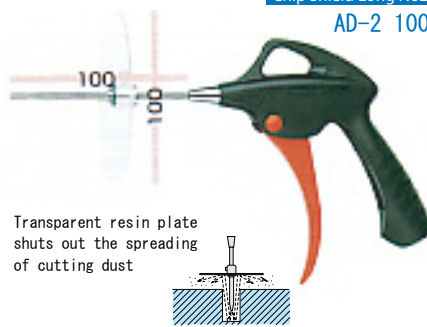

Transparent resin plate shuts out the spreading of cutting dust

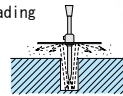

Air Screen Blow Prevents Dust and Articles Reflected

Air Screen Nozzle
AD-2 OC



Air curtain shuts out the spreading of oil, moisture and cutting dust

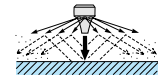

Low Pressured but for Large Air Flow

High Volume Nozzle
AD-2 OM

Air flow booster type
Venturi nozzle emits air to wider range 2.5 times more emission than #ON type

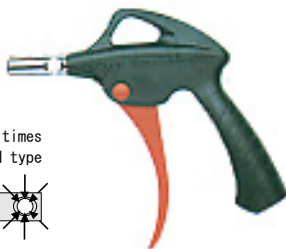
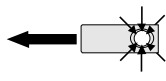

EDP No.	Model No.	Nozzle length	Nozzle length mm	O. A. L. mm	O. A. L. in.	Weight g	Weight lb.	Air consumption at 5kgf/cm ² r/min.	Pack/Box Size mm	Exterior
141111	AD-2 ON	Standard nozzle	0	145	5 23/32	116	0.27	135	152 × 232 × 30	10
141151	AD-2 ON-PB	Standard nozzle(with plug)	0	155	6 3/32	128	0.28	135	152 × 232 × 30	10
141112	AD-2 100N	Long nozzle	100	242	9 1/2	124	0.27	135	182 × 232 × 30	10
141152	AD-2 100N-PB	Long nozzle (with plug)	100	252	9 29/32	136	0.30	135	182 × 232 × 30	10
141113	AD-2 200N	Long nozzle	200	342	13 15/32	132	0.29	135	(Box) 140 × 455 × 30	1
141114	AD-2 300N	Long nozzle	300	442	19 3/8	140	0.31	135	(Box) 140 × 455 × 30	1
141115	AD-2 100A	25° Degree long nozzle	100	242	9 1/2	124	0.27	135	182 × 232 × 30	10
141116	AD-2 OR	Rubber tip nozzle	0	155.5	6 1/8	118	0.26	115	152 × 232 × 30	10
141117	AD-2 100R	Rubber tip long nozzle	100	227	8 5/16	141	0.31	115	182 × 232 × 30	10
141121	AD-2 OS	Safety by-pass nozzle	0	155.5	6 1/8	124	0.27	105	152 × 232 × 30	10
141122	AD-2 100S	Safety by-pass long nozzle	100	239.5	9 3/8	130	0.29	105	182 × 232 × 30	10
141120	AD-2 100P	Chip shield long nozzle	100	242	9 1/2	149	0.33	135	182 × 232 × 30	10
141118	AD-2 OM	High volume nozzle	0	160	6 9/32	121	0.27	185	152 × 232 × 30	10
141119	AD-2 OC	Air screen nozzle	0	145	5 23/32	117	0.26	260	152 × 232 × 30	10

*Power source ...Compressed air *Max. working pressure ... 9.9kgf/cm²(140 psi) *Working temperature range ... 0~ 60°C (32 ~ 140°F)

*Air Inlet screw diameter ... PT1/4 *Working air hose I.D. ... more than φ 4mm *Apply locally sold air coupling to this air inlet fitting (PT 1/4 male screw).

*Pre-packed (200N/300N in paper box)

CONTENTS

Blades (Spec. Blades) · · · · · 2, 5
 Blades (Standard Blades) · · · · · 3, 4
 Square Air Nipper (NS Series) · · · · · 6
 Air Nipper Round-Type Without Lever · · · · · 7
 Thrust-Cut Air Nipper (NK10) · · · · · 7
 Type-F Air Nipper (NF Series) · · · · · 8
 Double Action Air Nipper (NW/HW Series) · · · · · 8
 Slide-off Air Nipper Horizontal Type (NY-10S) · · · · · 9
 Slide-off Air Nipper Horizontal Type (NY Series) · · · · · 10

Slide-off Air Nipper Vertical-Type (NT Series) · · · · · 10
 Gate-Cut Table (ACT-30) · · · · · 11
 Timing Controller(TC-02) · · · · · 11
 Slide-off Air Nipper Bracket-Type (NB Series) · · · · · 12
 Heat Air Nipper (NTH/NKH Series) · · · · · 12
 Heat Air Nipper (GT-NH20S Series) · · · · · 14
 Hand Held Air Nipper (N Series) · · · · · 14
 Powerful Intensifier (Extra Pressure Booster/P Series) · · · · · 14

VESSEL Air Nipper / Blade System

Cutting, Crimping, Grasping, Breaking, Bending, Punching, Extending and Heat Cutting

VESSEL Air Nipper also can do other works. There are many other applications being not aware of. VESSEL can provide main body models, high-quality blades, optional blades, (even 1pc. can be manufactured) and other products to you. You can surely find out the main body model, blade or proper combination which are just fit to all works.

For machine mounting
 / With screw holes on 5 surfaces
 Square air nipper
 (NS series)

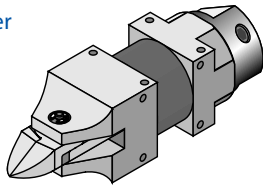

Possible to adjust fine turn angle
 / Convenient for mounting of holder. Etc.
 Air nipper round-type without lever (NR series)

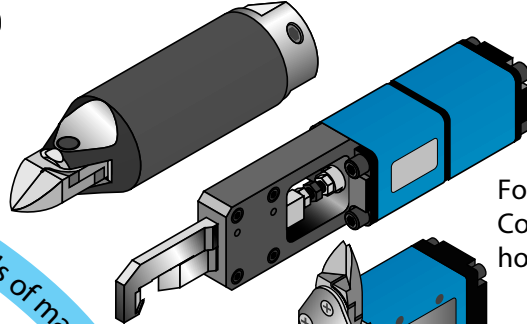

Thrust-cut type /
 Optimum for film gate cutting

Thrust-cut air nipper (NK10)

For mounting of machine jig/
 Compact body & with screw holes on 3 surfaces

F type air nipper (NF series)

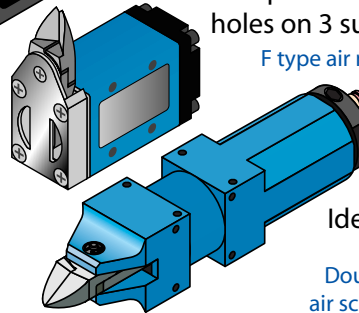

Ideal for consecutive working

Double action air nipper /
 air scissors (NW/HW series)

Horizontal type with slide-off mechanism / Cutting closer to work
 Slide-off air nipper horizontal-type (NY series)

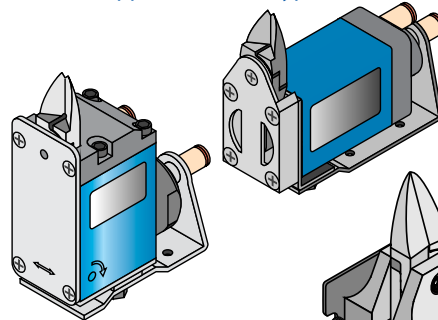

With slide-off mechanism /
 Cutting close to work for big materials

Slide-off air nipper
 bracket-type
 (NB series)

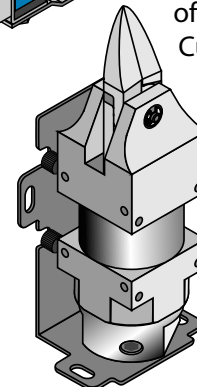

Vertical Type with
 slide-off mechanism/
 Cutting close to work
 Slide-off air nipper
 vertical type
 (NT series)

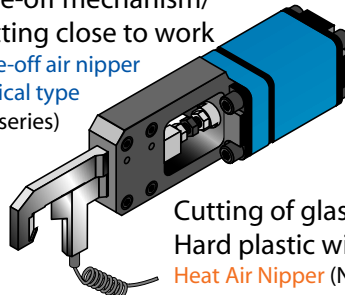

Cutting of glass fiber plastic/
 Hard plastic without whitening and crack
 Heat Air Nipper (NTH /NKH series)

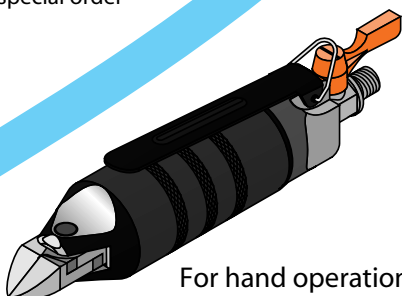

For hand operation
 Air nipper (N series)

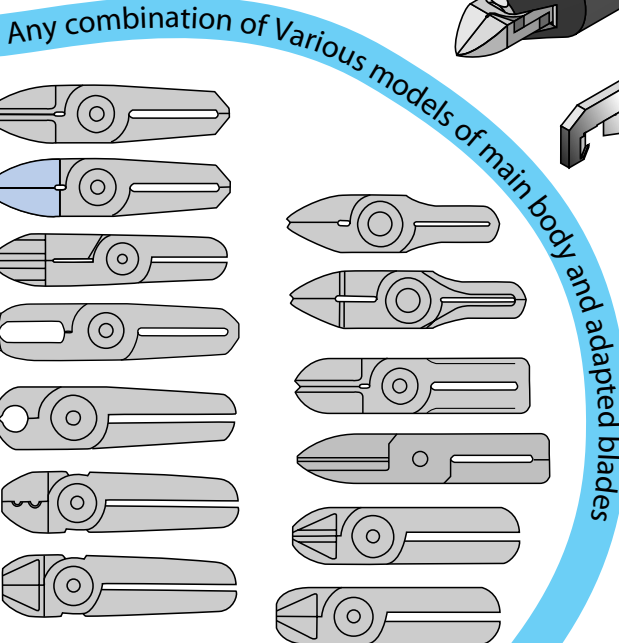

Any combination of Various models of main body and adapted blades

accept 1pc.
 special order

Peripheral Unit

- Gate cutting (at a time) for many quantity molded products.
 Gate cut table (ACT-30)
- For adjusting the timing of slide and cut
 Timing controller (TC-02)
- Increase of applying pressure by mounting to N / NS / NR
 Intensifier (P series)