

# Introduction



## Impactools

They're the hardest-working tools of all. Nothing cuts as much time, or packs more labor-saving power than the Impactool.

Imagine the manual process of a hammer striking against a hand wrench to tighten or loosen nuts and bolts. Then consider the sheer size and scope of those bolts — up to 4 inches in diameter — joining parts and components literally weighing tons, and exerting even greater forces. No small task, but one mastered by tools that create incredible energy out of compressed air or electricity, converting motor torque into a series of powerful rotary blows.

For almost seventy years, Ingersoll-Rand has pioneered the development and advancement of Impactools, and today leads the industry with the most complete product selection available. Throughout this catalog, you will find two different types of IR Impactools in three different performance rankings, designed to match the full spectrum of applications.

## Two Different Types

Conventional Impactools, in most cases, provide a torque output setting, but rely largely on operator judgment to determine when a fastener is sufficiently tightened. These are the most popular Impactools, and include air as well as electric models.

Torque Control Impactools (air only) provide automatic shutoff upon reaching a preset torque level. They are designed for applications requiring accurate fastener tightening, and incorporate built-in or detachable torsion bars. Based on their diameter and degree of adjustment, the torsion bar senses a predetermined torque level, and mechanically signals an internal shut-off device to prevent over-torquing.

## Three Different Rankings

Three different rankings help to define the IR line of Impactools:

- **Super Duty Tools** are intended for high volume production or heavy maintenance and construction, where ultimate performance and durability are required. These tools incorporate a number of unique added features, as well as the finest materials and bearings, tightest tolerances, and most powerful impact mechanisms.
- **Heavy Duty Tools** are well-suited to medium volume production or general maintenance and construction tasks, and offer a good balance between performance and economy.
- **Standard Duty Tools** are intended for less frequent use, involving lighter materials.

## Choices for Every Application

Still more choices exist, with a variety of Impactool configurations designed to suit the particular job at hand — for example ...small and medium-sized tools with straight or pistol-grip handles...and larger models with inside trigger, outside trigger, or lever throttle handles. Drive sizes range from 3/8-inch to 3 1/2-inch square drive, and also include spline drives for maximum power transmission in demanding applications. In addition, you can specify certain tools with quick-change anvils for use with extended socket devices, special screwdriver bits, wood augers, and more.

## Seventy Years of Leadership

Throughout its history, Ingersoll-Rand has earned a global reputation for creating tools that solve problems, build productivity, and put more power in the hands of the worker. The development of IR Impactools is a particularly strong case in point.

## Air Power

Invented by Robert Pott in the early 1930s, the first Impactool was electrically powered, and replaced a manual, labor-intensive process for applications in the agricultural industry. The tools quickly became popular in heavy industrial applications, proving their value in railroad maintenance, bridge construction, refineries, and many other roles. Ingersoll-Rand consulted with Pott and suggested the use of compressed air as a power source, with a new air motor package that the company had designed. Ingersoll-Rand later acquired the original Impactool patent

rights from Pott, and began testing its own designs. In 1934, IR introduced its first air Impactool models, in 3/4-inch drive sizes.

## Impactool Evolution

Several years later, IR replaced the original impact mechanism with its own ball and cam design, utilizing two steel balls trapped in opposing helical ball races on the hammer and cam. Shortly thereafter, IR replaced the gear-driven forward/reverse mechanism by simply changing the flow of air to the motor. This power package forms the basis for many of today's Impactools.

Throughout the 1950s and '60s, IR continued to expand its Impactool offerings as new and different applications arose. New advancements included the first torque control tools, designed to stop at predetermined settings, as well as numerous refinements to impact power mechanisms.

Ingersoll-Rand revolutionized Impactool design in the 1970s with the development of the twin-hammer mechanism, extracting more power with fewer moving parts than ever before. Two hammers strike instantaneous, balanced blows to the anvil lobes, generating increased torque with minimal vibration. And today, the advancements continue. The IR2904, 2131, and 2925 Series Models all deliver more power, comfort, and control than anything else in their respective classes. All reflect the IR philosophy of **High Performance Ergonomics** — user oriented design that provides real-world productivity benefits... based on a systematic, objective measure of ergonomic factors for validation and value.

In general, Ingersoll-Rand Impactool mechanisms can be identified by the first one or two digits of the model number:



- Twin-hammer: "2" (except 2902, 2903)
- Jumbo hammer: "17" (plus 2902, 2903)
- Ball and cam: "5" (plus electric Impacttools)

### Make the Right Choice

On the following pages, you will find a detailed review of the complete Ingersoll-Rand Impactool line, including performance specifications, special features, standard equipment, and relevant accessories. We have also provided an Impactool Selection Guide on pages 16-17. This will assist in the selection process by defining the following considerations:

- Diameter of fastener being used
- Grade of fastener being used
- Torque control vs. conventional
- Required torque (if applicable)



The selection guide will indicate recommendations based on types of fasteners and tools, using examples from the IR product line carrying the Super Duty rating. However, please refer to the tool specification pages for information on full line availability. In addition, check the Quick Reference on page 23.

**IR Impactools. The hardest-working tools of all, backed by the best support in the industry.**



High Performance Ergonomics

### Three Types of Impactool Mechanisms



#### Twin-Hammer

A simplified, yet highly effective design that holds each of the reversible hammers

in full engagement or disengagement with centrifugal force. The twin-hammer mechanism delivers more power per pound, and is less sensitive to air pressure fluctuations than any other design.

- Smooth, balanced blow
- High power-to-weight ratio
- Suitable for hard or soft-draw applications



#### Jumbo Hammer

Similar in concept to the twin-hammer mechanism, but employing a single hammer.

- Simplified design
- Reversible hammers
- Direct drive

#### Ball and Cam

Precision mechanism converts motor torque into powerful rotary impacts. A planetary gear drive delivers smooth, constant speed from the motor. The ball and cam mechanism is ideal for soft draw applications, and is utilized in larger Impacttools, as well as in all torque control and electric Impacttools.

- Air or electric
- Does not stall
- A time-tested design



### Configurations

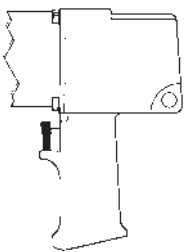

Pistol

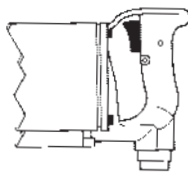

Inside Grip

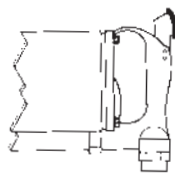

Outside Grip

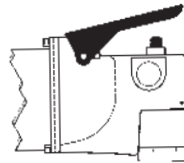

Straight

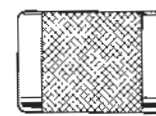

Quick Change



Square Drive



Spline Drive

## 3/8"-3/4" Class Impacttools

Ingersoll-Rand's wide range of Impacttools offers you the flexibility you need to fit even your most unique applications properly. From applications involving lighter materials and less frequent use to assembly or even maintenance, repair, and operation (MRO) applications, we've got the right tool for the job. Our product selection covers the full range of drive sizes and configurations. In this section, choose from 3/8-inch drive models such as the compact 2904 to IR's 3/4-inch class Series 2925.



# 3/8" Class Impacttools



● 2902P1



■ 1702P4



▲ 2904P1



★ 1702SB1

Hanger not included

## Features

- Twin-hammer impact mechanism on Series 2904
- Jumbo Hammer impact mechanism on Series 2902 and 1702
- Durable epoxy-coated motor housing and handle
- Plated steel hammer case
- Pressure-feed impact mechanism lubrication

## Standard Equipment

### Series 2902 and 2903

- 1/4" NPT inlet
- Steel hammer case
- Integral muffler
- Built-in power regulator
- Pin-type socket retainer

### Series 2904

- 1/4" NPT inlet
- Steel hammer case
- Composite housing
- Power management system

## Series 1702

- 1/4" NPT inlet
- Steel hammer case
- B1 and B3 model: Inside throttle and dead handle
- Pin-type socket retainer
- Built-in power regulator (P)

## Equipment at Extra Price

- Vertical hanger No. 1901-365 (B)
- Exhaust muffler kit No. 212-K23 (P)
- Horizontal hanger No. 1901-366

## Series 2902

- Vertical hanger No. 1901-365 (B)
- Horizontal hanger No. 1901-366 (P&B)

## Series 2903

- Vertical hanger No. 2908-365
- Horizontal hanger No. 1901-366

Model	Drive Description	Handle	Free Speed rpm	Impacts per minute	Maximum Torque		Recomm. Torque Range		Weight, less socket		Length, less socket		Side to Center Distance		Size Hose	Recomm. CFM
					ft.-lb.	Nm	ft.-lb.	Nm	lb.	kg	in.	mm	in.	mm	in. mm	
<b>Super Duty Impacttools</b>																
● 2902P1	3/8" square	Pistol	10,000	1500	140	190	20-120	27-163	2 1/2	1.25	5 1/2	140	1 3/8	35	5/16 8	15
2903P2	3/8" square	Pistol	6000	1200	205	278	30-170	41-230	4 13/16	2.18	5 5/8	143	1 3/8	35	3/8 10	21
▲ 2904P1	3/8" square	Pistol	14,500	1500	230	313	25-200	34-270	2.65	1.20	5 3/4	146	1 1/8	29	3/8 10	18
	Reverse Bias				260	354										
2904P4	1/4" hex QC	Pistol	14,500	1500	260	354	25-200	34-270	2.65	1.20	5 3/4	146	1 1/8	29	3/8 10	18
	Reverse Bias															
<b>Heavy Duty Impacttools</b>																
★1702SB1	3/8" square	Straight	10,000	1500	105	142	13-85	18-115	2 1/2	1.12	5 7/8	149	1	25	5/16 8	13
1702P1	3/8" square	Pistol	10,000	1500	125	170	20-100	27-136	2 3/4	1.25	5 1/2	140	1 3/8	35	5/16 8	15
■ 1702P4	1/4" hex QC	Pistol	10,000	1500	125	170	20-100	27-136	2 3/4	1.25	5 1/2	140	1 3/8	35	5/16 8	15

"QC" designates a Quick Change chuck.

Note: All of the above square drive Impacttools furnished with pin-type retainer. Performance figures are at 90 psi (620kPa) air pressure.

# 1/2" Class Impacttools

## Features

- Jumbo hammer impact mechanism on Series 2903
- Rugged twin-hammer impact mechanism on 2906
- Durable epoxy-coated motor housing and handle
- Plated steel hammer case
- Pressure-feed impact mechanism lubrication

## Standard Equipment

### Series 2903

- 1/4" NPT inlet
- Steel hammer case
- Built-in lubricator
- Integral muffler
- Built-in power regulator

### Series 2131

- 1/4" NPT inlet
- Steel hammer case
- Composite housing
- Built-in power regulator

### Series 2906

- 1/4" NPT inlet
- Steel hammer case
- Built-in lubricator
- Integral muffler
- Two-piece motor housing
- Built-in power regulator



▲ 2903P1



★ 2906P1

### Series 2707

- 1/4" NPT inlet
- Steel hammer case
- Built-in power regulator

### Models 2705A1

- 1/4" NPT inlet
- Steel hammer case
- Built-in power regulator



● 2131P

## Equipment at Extra Price

### Series 2903, 2908

- Vertical hanger No. 2908-365

### Series 2705

- Vertical hanger No. 904-366

### Series 2131

- Vertical hanger No. 2131-366

Model	Drive Description	Handle	Free Speed rpm	Impacts per minute	Maximum Torque		Recomm. Torque Range		Weight, less socket		Length, less socket		Side to Center Distance		Size Hose Recomm. CFM		
					ft.-lb.	Nm	ft.-lb.	Nm	lb.	kg	in.	mm	in.	mm	in.	mm	
<b>Super Duty Impacttools</b>																	
★ 2906P1	1/2" square	Pistol	5000	1200	500	678	40-350	54.2-475	6	2.72	67/8	175	11 <sup>11</sup> / <sub>32</sub>	34	3/8	10	23
▲ 2903P1	1/2" square	Pistol	6000	1200	220	298	30-185	41-250	4 <sup>3</sup> / <sub>16</sub>	2.18	5 <sup>5</sup> / <sub>8</sub>	143	1 <sup>3</sup> / <sub>8</sub>	35	3/8	10	21
<b>Heavy Duty Impacttools</b>																	
2707A1	1/2" square	Pistol	7750	1300	450	610	40-275	54-373	6	2.72	6 <sup>1</sup> / <sub>2</sub>	165	1 <sup>3</sup> / <sub>8</sub>	35	5/16	8	26
<b>Standard Duty Impacttools</b>																	
● 2131P	1/2" square Reverse Bias	Pistol	9500	1200	450	610	50-400	68-542	4 <sup>1</sup> / <sub>2</sub>	2.04	6 <sup>7</sup> / <sub>8</sub>	174	1 <sup>3</sup> / <sub>8</sub>	35	3/8	10	27
2131P7	7/16" hex QC Reverse Bias	Pistol	9500	1200	450	610	50-400	68-542	4 <sup>1</sup> / <sub>2</sub>	2.04	6 <sup>7</sup> / <sub>8</sub>	174	1 <sup>3</sup> / <sub>8</sub>	35	3/8	10	27
2705A1	1/2" square	Pistol	8500	1200	400	542	40-200	54-271	5 <sup>5</sup> / <sub>8</sub>	2.55	6 <sup>3</sup> / <sub>4</sub>	171	11 <sup>11</sup> / <sub>32</sub>	34	3/8	10	23
2904P2	1/2" square Reverse Bias	Pistol	14,500	1500	230	313	25-200	34-270	2.65	1.20	5 <sup>3</sup> / <sub>4</sub>	146	1 <sup>1</sup> / <sub>8</sub>	29	3/8	10	18

All of the above square drive Impacttools furnished with pin-type retainer. Performance figures are at 90 psi (620 kPa) air pressure.

# 5/8" and 3/4" Class Impacttools

## Introducing the IR2925B.

**1700 ft.- lbs. of max torque ÷ 14 lbs. of tool**

With an ergonomically designed handle and grip, and a trim, 14-lb. weight, the IR2925B 1" Impacttool will ease the burden of exhausting steel erection, bridge maintenance, power generation and petrochemical applications.



Standard dead handle allows a comfortable and balanced grip, with even weight distribution. Adjustable 360° positioning.

Although it weighs approximately 30% less than the lightest competitor, the IR2925B generates an incredible 1700 ft.-lbs. of torque in reverse, thanks to a compact, efficient air motor that achieves peak torque output quicker than other tools.

Other features include the Corrode-X corrosion resistant motor, valving and airflow components, Ingersoll-Rand's enhanced geometry twin-hammer mechanism, an easy-access power management system, and a rear air inlet that keeps the hose in line and out of the way.

The IR2925B – More power – More speed – More comfort – Less weight. Forward bias and outside trigger models are also available. And, the IR2925P Series offers similar advantages in a pistol-grip configuration.



The three-position power management system is conveniently located inside the handle for one-handed access to three levels of power in forward, and one in reverse.



**Steel hammer case**  
Provides excellent durability.

**Durable, textured epoxy finish**  
Adds a non-slip grip and premium appearance to the cast aluminum housing and rear handle.

**Ergonomically-designed handle**  
Provides a comfortable, secure grip and excellent control. Designed specifically for tough, industrial applications.

**Enhanced twin-hammer impact mechanism (patented design)**  
Ingersoll-Rand® introduced the original twin-hammer impact mechanism, and we've continually refined it for smooth, efficient power delivery and long life. Only four moving parts.

**Corrode-X™ component package**  
Protects motor, valving, and airflow components from airborne atmosphere contaminants to keep the tool running under the most adverse conditions.

**Reverse bias 7-vane high-output air motor**  
High efficiency motor quickly delivers a maximum torque of 1700 ft. - lbs. in reverse.

**Throughbolt design**  
Facilitates fast, easy maintenance; eliminates sharp edges and protrusions on the housing.

**Bottom exhaust with muffler**  
45° angle directs air safely away from the operator and the work.

**Three-position power management system**  
Conveniently located inside handle for one-handed access to three levels of power in forward mode, one in reverse.

**Universal grease fitting**  
Offers quick, easy maintenance (Shown on other side)

**1/2" swivel air inlet**  
Large capacity, improves air flow, increases power, and eliminates twisting for greater maneuverability.

# IR2925P

## A new generation of Impacttools

The unique features of the 2925 Series extend to pistol grip configurations in the 2925P Models. They offer an unmatched combination of performance and control, with the durability to withstand the toughest operating conditions.

### External features include:

- Ergonomic handle design
  - Smooth contoured profile with integral grip ledge
  - Three-piece housing
  - Handle exhaust
  - 360° swivel air inlet
  - Contoured trigger
  - Minimum side-to-center distance
  - Enhanced pressure-feed lubrication system
  - Low profile reverse lever
  - Three-position power regulation and forward/reverse control
- Position #1 = Full  
 #2 = Approx. 88%  
 #3 = Approx. 77%

### Internal features include:

- 1 Enhanced twin-hammer impact mechanism
- 2 Supermotor™
- 3 Through-bolt construction
- 4 Corrode-X™ (Components completely impervious to corrosive contaminants)
- 5 Tilt throttle
- 6 Reverse or forward bias
- 7 Concentric cylinder design
- 8 Composite vanes
- 9 Balanced horizontal suspension bail (opt.)
- 10 Piped-away exhaust (opt.)

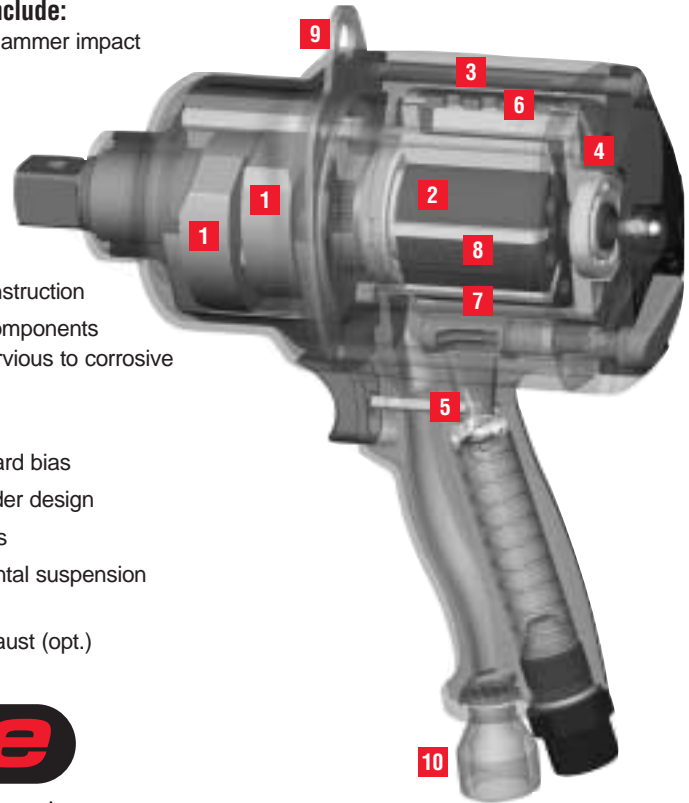

High Performance Ergonomics

# IR2161

## The IR2161 models

The IR2161 heavy duty models are ideal for applications a little less demanding than those for the IR2925.

Features that distinguish the IR2161 from the IR2925 models include:

- Enhanced single-hammer mechanism
  - Contoured trigger
  - Minimum side-to-center distance
  - Enhanced pressure-feed lubrication system
  - Three-position power regulation and forward/reverse control
  - Ribbed lever surface
- Position #1 = Full  
 #2 = Approx. 88%  
 #3 = Approx. 77%



- Maximum torque of 1250 ft.-lbs.
- Smooth, high-gloss cast aluminum finish
- 6-Vane high-output air motor
- Smooth, contoured exterior profile

### External features include:

- Ergonomic handle design
- Smooth contoured profile
- Three-piece housing
- Handle exhaust
- 360° swivel air inlet

### Internal features include:

- An enhancement to the original single-hammer mechanism provides increased durability and performance (patent applied for)
- 6-Vane high-output air motor
- Through-bolt construction
- 360° swivel air inlet
- Tilt throttle
- Concentric cylinder design
- Balanced horizontal suspension bail (opt.)
- Piped-away exhaust (opt.)



## 5/8" and 3/4" Class Impacttools



◆ 2925B2



■ 2925P1

### Features

#### Models 2161P, 2171P

- Conventional cast aluminum finish
- Full contoured housing shape
- Ergonomically-designed handle
- 360° swivel inlet
- Handle exhaust
- Enhanced single-hammer impact mechanism
- 6-Vane high-output air motor

#### Series 2908

- Durable epoxy-coated motor housing and handle
- Plated steel hammer case
- Twin-hammer impact mechanism
- Pressure-feed impact mechanism lubrication

#### Series 2920B

- Muffled exhaust reduces operator fatigue
- Slip fit motor for easy maintenance
- Tilt throttle on pistol models for maximum control
- Two-piece motor housing on pistol models
- Durable epoxy-coated motor housing and handle
- Plated steel hammer case
- Twin-hammer impact mechanism
- Pressure-feed impact mechanism lubrication

#### Series 2925

- Integral grip ledge
- Three-piece housing
- Handle exhaust
- Minimum side to center distance
- Three position power regulation
- Forward/reverse control
- Enhanced twin-hammer impact mechanism
- 7-Vane high-output air motor
- Corrode-X™

#### Series 2925B

- 1/2" swivel air inlet
- Enhanced twin-hammer impact mechanism

- Corrode-X™ component package
- Reverse bias 7-vane high-output air motor
- Throughbolt design
- 45° bottom exhaust with muffler
- Three-position power management system
- Universal grease fitting
- Steel hammer case
- Durable, textured epoxy finish
- Ergonomically-designed handle

### Standard Equipment

#### Models 2161P, 2171P

- 3/8" NPT inlet
- Steel hammer case
- Integral muffler
- Built-in power regulator
- Through-hole socket retainer

#### Series 2908

- 3/8" NPT Inlet
- Pin-type socket retainer
- Steel hammer case
- Integral muffler
- Built-in lubricator
- Built-in power regulator

#### Series 2925

- 3/8" NPT Inlet
- Steel hammer case
- Integral muffler
- Built-in power regulator
- Through-hole socket retainer

#### Series 2920B

- 3/8" NPT inlet
- Steel hammer case
- Integral muffler
- Built-in lubricator
- 90° Angle drive (Model 2920B9 only)
- 2920B3 includes 834-48 straight handle
- 2920B9 includes spade handle T15-41

#### Series 1720

- 3/8" NPT inlet
- Steel hammer case

- B3 model: Inside throttle and dead handle

### Equipment at Extra Price

#### Models 2161P, 2171P

- Piped-away exhaust kit No. 2161-123
- Horizontal suspension bail No. 2161-366
- Boot 2161-P32

#### Series 2908

- Vertical hanger No. 2908-365

#### Series 2925

- Piped-away exhaust kit No. 2161-123
- Horizontal suspension bail No. 2161-366
- Number 4 spline anvil No. 2910-A526

#### Series 2920B

- 2910B-726-6: 6" extended 3/4" anvil
- Horizontal hanger No. 910-366
- 5/8" hex quick change anvil No. 2910B-A926-10

#### Series 2920B

- Power regulator valve kit No. 2920-K32

#### Series 1720

- 3/4" drive x 6" (152 mm) hog ring style
- Extended anvil No. 265-A626-6
- Horizontal hanger No. 910-366
- Power regulator Kit No. 2920-K329
- Reverse valve Kit No. 1720-K329
- Dead handle 834-48
- Dead handle bracket 2910B-364

(Please turn page for specifications)

# 5/8" and 3/4" Class Impacttools

Model	Drive Description	Handle	Free Speed rpm	Impacts per minute	Maximum Torque		Recomm. Torque Range		Weight, less socket		Length, less socket		Side to Center Distance		Size Hose Recomm. CFM		
					ft.-lb.	Nm	ft.-lb.	Nm	lb.	kg	in.	mm	in.	mm	in.	mm	
<b>Super Duty Impacttools</b>																	
2925P1	3/4" square	Pistol	5200	1050	1450	1972	350-1100	476-1496	11 <sup>7</sup> / <sub>8</sub>	5.39	8 <sup>7</sup> / <sub>8</sub>	225	1 <sup>3</sup> / <sub>4</sub>	44	1/2	13	60
2925P3	1" square	Pistol	5200	1050	1450	1972	350-1100	476-1496	11 <sup>7</sup> / <sub>8</sub>	5.39	8 <sup>7</sup> / <sub>8</sub>	225	1 <sup>3</sup> / <sub>4</sub>	44	1/2	13	60
2925RBP1	3/4" square Reverse Bias	Pistol	5200	1050	1600 R 1300 F	2176 1768	400-1400 300-950	544-1904 408-1292	11 <sup>7</sup> / <sub>8</sub>	5.39	8 <sup>7</sup> / <sub>8</sub>	225	1 <sup>3</sup> / <sub>4</sub>	44	1/2	13	60
2925B2	1" square	Grip I.T.	6500	900	1600	2170	350-1400	475-1904	14	6.35	12 <sup>3</sup> / <sub>8</sub>	314	1 <sup>5</sup> / <sub>8</sub>	41	1 <sup>1</sup> / <sub>2</sub>	13	60
2925RB2	1" square Reverse Bias	Grip I.T.	6500	900	1700 1500	2305 2034	F300-1300 R400-1500	407-1763 544-2034	14	6.35	12 <sup>3</sup> / <sub>8</sub>	314	1 <sup>5</sup> / <sub>8</sub>	41	1 <sup>1</sup> / <sub>2</sub>	13	60
2925A2	1" square	Grip O.T.	6500	900	1600	2170	350-1400	475-1904	14	6.35	12 <sup>3</sup> / <sub>8</sub>	314	1 <sup>5</sup> / <sub>8</sub>	41	1 <sup>1</sup> / <sub>2</sub>	13	60
2925RA2	1" square Reverse Bias	Grip O.T.	6500	900	1700 1500	2305 2034	F300-1300 R400-1500	407-1763 544-1904	14	6.35	12 <sup>3</sup> / <sub>8</sub>	314	1 <sup>5</sup> / <sub>8</sub>	41	1 <sup>1</sup> / <sub>2</sub>	13	60
2925RBP3	1" square Reverse Bias	Pistol	5200	1050	1600 R 1300 F	2176 1768	400-1400 300-950	544-1904 408-1292	11 <sup>7</sup> / <sub>8</sub>	5.39	8 <sup>7</sup> / <sub>8</sub>	225	1 <sup>3</sup> / <sub>4</sub>	44	1/2	13	60
2920B1	3/4" square	Grip	5000	950	1100	1495	250-800	339-1085	13 <sup>3</sup> / <sub>16</sub>	5.98	12 <sup>1</sup> / <sub>2</sub>	318	1 <sup>29</sup> / <sub>32</sub>	49	1/2	13	36
2920B3	1" square	Grip	5000	950	1100	1495	250-800	339-1085	13 <sup>3</sup> / <sub>16</sub>	5.98	12 <sup>1</sup> / <sub>2</sub>	318	1 <sup>29</sup> / <sub>32</sub>	49	1/2	13	36
◆2920B9	3/4" sq. at 90°	Grip	5000	950	550	949	125-400	203-678	23 <sup>11</sup> / <sub>16</sub>	10.75	17 <sup>1</sup> / <sub>2</sub>	445	1 <sup>15</sup> / <sub>16</sub>	†33	1/2	13	36
2908P2	3/4" square	Pistol	6000	1050	750	1017	100-450	136-610	8 <sup>11</sup> / <sub>16</sub>	3.94	7 <sup>11</sup> / <sub>16</sub>	195	1 <sup>5</sup> / <sub>8</sub>	41	1/2	13	31
2908P1	5/8" square	Pistol	6000	1050	750	1017	100-450	136-610	8 <sup>1</sup> / <sub>2</sub>	3.86	7 <sup>11</sup> / <sub>16</sub>	195	1 <sup>5</sup> / <sub>8</sub>	41	1/2	13	31
<b>Heavy Duty Impacttools</b>																	
2161P	3/4" square	Pistol	5750	1025	1250	1700	250-900	340-1224	11 <sup>1</sup> / <sub>4</sub>	5.10	8 <sup>1</sup> / <sub>2</sub>	216	1 <sup>3</sup> / <sub>4</sub>	44	1/2	13	55
2171P	1" square	Pistol	5750	1025	1250	1700	250-900	340-1224	11 <sup>1</sup> / <sub>4</sub>	5.10	8 <sup>1</sup> / <sub>2</sub>	216	1 <sup>3</sup> / <sub>4</sub>	44	1/2	13	55
1720P1	3/4" square	Pistol	5500	1000	1000	1360	200-600	271-813	11 <sup>7</sup> / <sub>8</sub>	5.39	7 <sup>5</sup> / <sub>8</sub>	194	1 <sup>29</sup> / <sub>32</sub>	48	1/2	13	40
1720P3	1" square	Pistol	5500	1000	1100	1490	250-750	340-1016	11 <sup>7</sup> / <sub>8</sub>	5.39	7 <sup>5</sup> / <sub>8</sub>	194	1 <sup>29</sup> / <sub>32</sub>	48	1/2	13	40
1720B1	3/4" square	Grip	5500	1000	1000	1360	200-600	271-813	13 <sup>3</sup> / <sub>16</sub>	6.27	11 <sup>3</sup> / <sub>4</sub>	299	1 <sup>29</sup> / <sub>32</sub>	48	1/2	13	40
1720B3	1" square	Grip	5500	1000	1100	1490	250-750	340-1016	13 <sup>3</sup> / <sub>16</sub>	6.27	11 <sup>3</sup> / <sub>4</sub>	299	1 <sup>29</sup> / <sub>32</sub>	48	1/2	13	40

Note: IR2925 number 4 spline models are available by converting the standard square drive anvil with number 4 spline anvil part number 2910-A526. The same performance figures apply.

Models 2908P1 and 2908P2 Impacttools furnished with pin-type retainer.

Performance figures are at 90 psi (620 kPa) air pressure.

Angle head gear ratio on model 2920B9 is 2 to 1.

† Side to center distance of angle head. Height of angle head to shoulder of square drive is 3<sup>1</sup>/<sub>2</sub>" (89 mm).

\*\*2920B9 Hammer Case is plated ductile iron.

◆ Approx. 50% torque reduction.

I.T.: Inside Throttle

O.T.: Outside Throttle