

# AFD Product Range

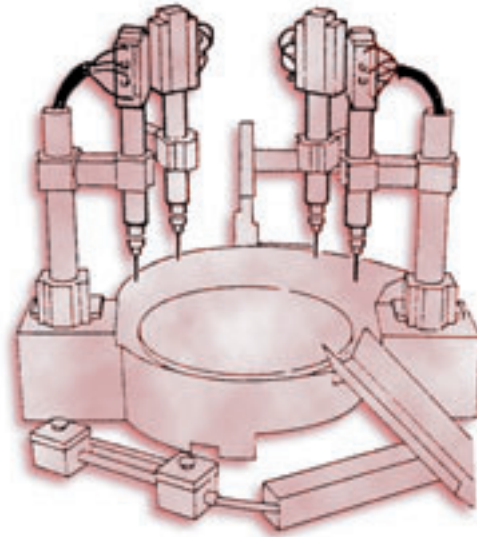

## Ease of Incorporation into Machine or Process

- Extensive range of mounting clamps
- Control interfaces to link AFD(E) to other equipment through pneumatics or electrically
- Single signal required for AFD(E) to perform cycle
- Output signals at datum and depth
- Electric motor mounting on 200, 400 and 600 series can be rotated through 180°

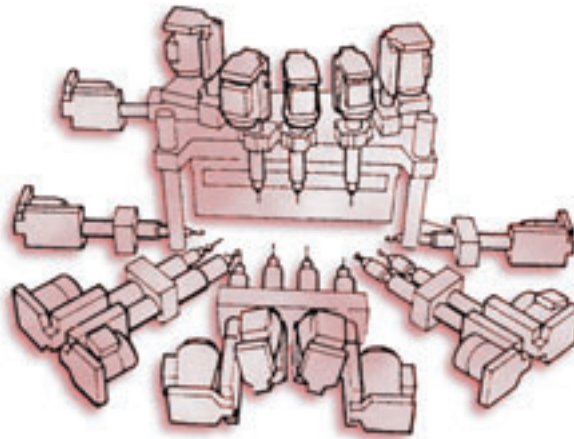

## Modular Design

- Flexibility of unit function and speed
- Common components in differing models reducing inventory
- Multiple spindle head options
- Drill and tapping options for all models

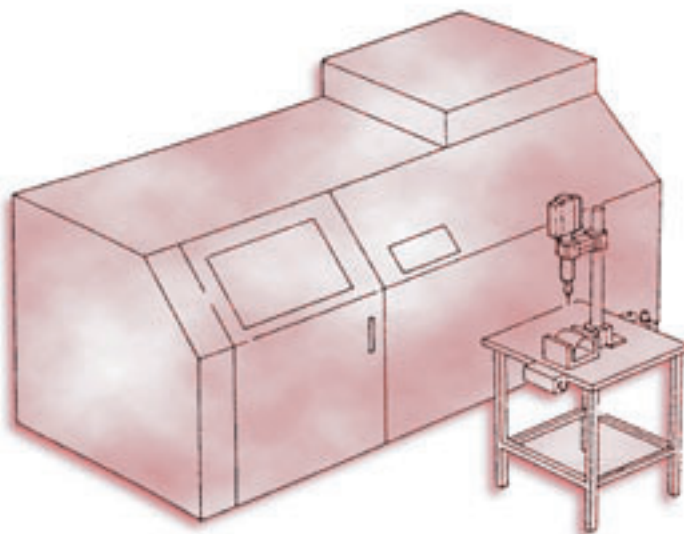

## Comprehensive range of Products

- For single spindle operations to multi spindle processes
- Pneumatic and electric drive from 0.22 to 0.75W (0.3-1.0hp) with thrusts from 320 to 1557N (72-350lbf)
- Reliability through quality



For further information see catalogue LT1212

## Electric drive / Pneumatic feed



| MODEL   | MOTOR POWER |      | DYNAMIC THRUST |     | FREE SPEED | WORKING STROKE |      | FUNCTION     |
|---------|-------------|------|----------------|-----|------------|----------------|------|--------------|
|         | kW          | hp   | N              | lbf | rpm        | mm             | in.  |              |
| AFDE200 | 0.25        | 0.34 | 320            | 72  | 850-11950  | 90             | 3.43 | Drill/Tapper |



| MODEL   | MOTOR POWER |      | DYNAMIC THRUST |     | FREE SPEED | WORKING STROKE |      | FUNCTION     |
|---------|-------------|------|----------------|-----|------------|----------------|------|--------------|
|         | kW          | hp   | N              | lbf | rpm        | mm             | in.  |              |
| AFDE410 | 0.75        | 1.00 | 724            | 163 | 330-9600   | 100            | 3.94 | Drill/Tapper |



| MODEL   | MOTOR POWER |      | DYNAMIC THRUST |     | FREE SPEED | WORKING STROKE |      | FUNCTION     |
|---------|-------------|------|----------------|-----|------------|----------------|------|--------------|
|         | kW          | hp   | N              | lbf | rpm        | mm             | in.  |              |
| AFDE610 | 0.75        | 1.00 | 1557           | 350 | 330-6300   | 100            | 3.94 | Drill/Tapper |

## Electric drive / Leadscrew feed



| MODEL   | MOTOR POWER |      | TAPPING TORQUE |         | FREE SPEED | WORKING STROKE |      | FUNCTION |
|---------|-------------|------|----------------|---------|------------|----------------|------|----------|
|         | kW          | hp   | Nm             | lbf ins | rpm        | mm             | in.  |          |
| AFTE480 | 0.75        | 1.00 | 4.4-35.8       | 39-317  | 180-1740   | 60             | 2.36 | Tapper   |

## Pneumatic drive / feed



| MODEL  | MOTOR POWER |      | DYNAMIC THRUST |     | FREE SPEED | WORKING STROKE |      | FUNCTION     |
|--------|-------------|------|----------------|-----|------------|----------------|------|--------------|
|        | kW          | hp   | N              | lbf | rpm        | mm             | in.  |              |
| AFD205 | 0.22        | 0.30 | 400            | 90  | 650-18700  | 50             | 1.97 | Drill/Tapper |



| MODEL  | MOTOR POWER |      | DYNAMIC THRUST |     | FREE SPEED | WORKING STROKE |      | FUNCTION     |
|--------|-------------|------|----------------|-----|------------|----------------|------|--------------|
|        | kW          | hp   | N              | lbf | rpm        | mm             | in.  |              |
| AFD215 | 0.22        | 0.30 | 400            | 90  | 650-18700  | 90             | 3.43 | Drill/Tapper |



| MODEL  | MOTOR POWER |      | DYNAMIC THRUST |     | FREE SPEED | WORKING STROKE |      | FUNCTION     |
|--------|-------------|------|----------------|-----|------------|----------------|------|--------------|
|        | kW          | hp   | N              | lbf | rpm        | mm             | in.  |              |
| AFD415 | 0.38        | 0.51 | 706            | 159 | 490-18000  | 100            | 3.94 | Drill/Tapper |



| MODEL  | MOTOR POWER |      | DYNAMIC THRUST |     | FREE SPEED | WORKING STROKE |      | FUNCTION     |
|--------|-------------|------|----------------|-----|------------|----------------|------|--------------|
|        | kW          | hp   | N              | lbf | rpm        | mm             | in.  |              |
| AFD625 | 0.66        | 0.85 | 1557           | 350 | 40-3300    | 100            | 3.94 | Drill/Tapper |

