

# Function Fittings, Flow Controls, and Accessory Valves



12 VA0 Right Angle (Banjo) Flow Control (inch-knob adj.) . .FIT-3-3  
 12 VB0 Right Angle (Banjo) Flow Control (inch-slot adj.) . .FIT-3-3  
 10 TA0 Right Angle (Banjo) Flow Control (metric-knob adj.) FIT-3-4  
 10 K51 Right Angle (Banjo) Flow Control (metric-slot adj.) . .FIT-3-4  
 T1000 In-line Flow Control (NPT and ISO G) . . . . .FIT-3-6  
 T15 Push-In Flow Regulators . . . . .FIT-3-8  
 M/800, C/800 Heavy Duty In-Line Flow Control . . . . .FIT-3-10  
 M/600, C/600 Heavy Duty In-Line Flow Control . . . . .FIT-3-12  
 M/650, C/650, M/677, C/677 Precision Flow Controls . . . . .FIT-3-14  
 T51/T52/T53 Series, PIF Non Return Valves . . . . .FIT-3-16  
 T55, T56 Non-Return Valves . . . . .FIT-3-16  
 T60 Air Fuse (Excess Flow Check) (NPT and ISO G) . . . . .FIT-3-18  
 Pressure Reducing Fitting (inch and metric) . . . . .FIT-3-23  
 Pilot Operated Check Valve (inch and metric) . . . . .FIT-3-26  
 Pressure Sensor Fitting (inch and metric) . . . . .FIT-3-28  
 T70 Quick Exhaust Valves (NPT and ISO G) . . . . .FIT-3-30  
 T65 1/8" and 1/4" Shuttle Valves (NPT and ISO G) . . . . .FIT-3-32

- 360° rotation of the banjo body around the bolt allows for ideal positioning of tubing.
- Low profile and reduced physical size provide space saving installations, while internal configuration provides the flow capacity of much bulkier designs.
- Tapered adjustment needles with large adjustment ranges provide linear flows and greater precision.
- Knurled adjustment knobs (w/screw driver slot) and lock nuts on 12 VA0 and 10 TA0 series provide finger tip adjustment. Tamper resistance on the 12 VBO and 10 K51 is provided by a slotted adjustment screw covered by a protective plastic cap.
- Direct mounting of flow controls on pneumatic actuators minimizes the adjustment problems encountered due to the compressibility of air in long tubing runs between the actuator and control valving. Additionally, direct mounted flow controls end the confusion over which actuator in a circuit is being controlled.
- Metallic components are limited to nickel plated all brass construction, eliminating the potential problems encountered with products constructed of dissimilar metals.
- Adjustment needles and banjo bodies are retained, preventing accidental loss of the needle or lock nut.



### Operation:

Flow Controls are checked adjustable controls of the meter out type. Compressed air passes freely into the push-in fitting portion of the flow control, flowing past the check seal and entering the connected component. In reverse flow conditions, air passes back into the flow control and energizes the check seal. Air must now flow through the metered passage controlled by the tapered adjustment needle of the flow control, and finally exits through the push-in fitting end.

### Specifications

Fluid: Compressed air.

**Note:** For other types of fluids or compressed gases, please consult factory.

Working Pressure: 5 to 150 psig (.3 to 10 bar)

Temperature Range: 0° to 175°F (-20° to 80°C)

### Materials of Construction:

Banjo bolt, collet, adjustment knob and lock nut: Nickel plated brass

Tapered adjusting needle: Brass

Banjo Body, 12 VA0 XXXX and 10 TA0: Thermoplastic

12 VBO and 10 K51 XXXX: Nickel plated brass

O-rings and check-seal: Silicone free Nitrile

Sealing washer: Thermoplastic (ISO G and 10-32 UNF)

Tubing: Nylon 11 or 12, 95 durometer polyurethane.

Thread Sealant: Thread sealant is applied to the full circumference of tapered male threads.

### Options

Special versions of the flow controls are available, including meter-in (12 WA0 Series) and bi-directional control configurations. Please consult factory with specific quantities and requirements.

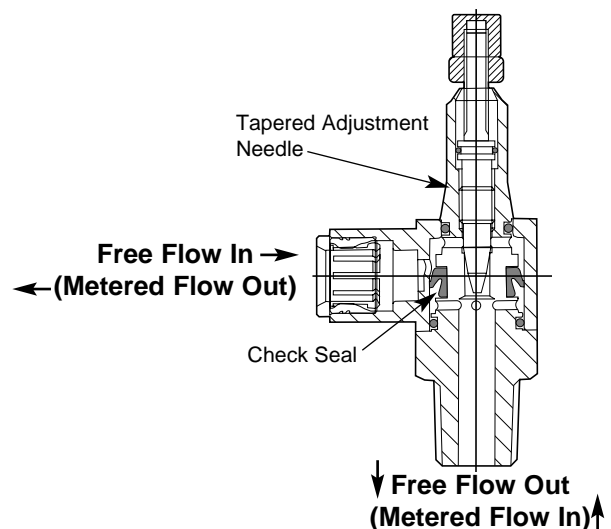

### Pneumatic Symbol

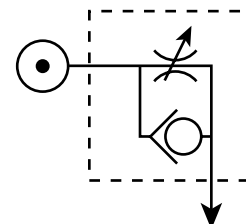



**VAO Series**

Dimensions in Inches (mm)

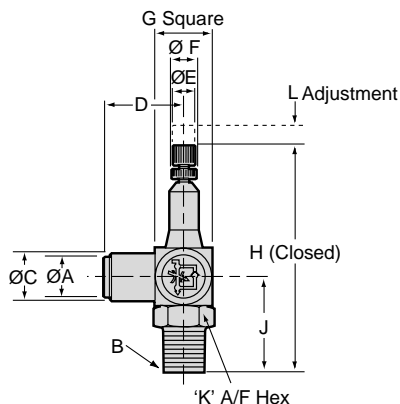

A Tube O.D.	B NPT or UNF Thread	Part Number	C	D	E	F	G	H	J	K A/F	L Adj
5/32"	10-32 UNF	<b>12 VAO 0210</b>	0.37 (9.5)	1.04 (26.5)	0.16 (4.0)	0.74 (18.7)	0.38 (9.5)	1.51 (38.4)	0.45 (11.4)	-	0.12 (3.0)
	1/8	<b>12 VAO 0218</b>	0.45 (11.5)	0.87 (22.0)	0.31 (8.0)	0.35 (9.0)	0.63 (16.0)	2.09 (53.0)	0.89 (22.5)	9/16"	0.12 (3.0)
1/4"	1/8	<b>12 VAO 0418</b>	0.51 (13.0)	0.91 (23.0)	0.31 (8.0)	0.35 (9.0)	0.63 (16.0)	2.09 (53.0)	0.89 (22.5)	9/16"	0.12 (3.0)
	1/4	<b>12 VAO 0428</b>	0.53 (13.5)	1.00 (25.5)	0.39 (10.0)	0.43 (11.0)	0.79 (20.0)	2.64 (67.0)	1.16 (29.5)	11/16"	0.24 (6.0)
3/8"	1/4	<b>12 VAO 0628</b>	0.77 (19.5)	1.24 (31.5)	0.39 (10.0)	0.43 (11.0)	0.79 (20.0)	2.64 (67.0)	1.16 (29.5)	11/16"	0.24 (6.0)
	3/8	<b>12 VAO 0638</b>	0.77 (19.5)	1.28 (32.5)	0.47 (12.0)	0.51 (13.0)	0.87 (22.0)	3.07 (78.0)	1.30 (33.0)	3/4"	0.24 (6.0)
1/2"	1/2"	<b>12 VAO 0748</b>	0.91 (23.0)	1.50 (38.0)	0.63 (16.0)	0.71 (18.0)	1.06 (27.0)	3.66 (93.0)	1.65 (42.0)	7/8"	0.28 (7.0)

**VB0 Series**

Dimensions in Inches (mm)

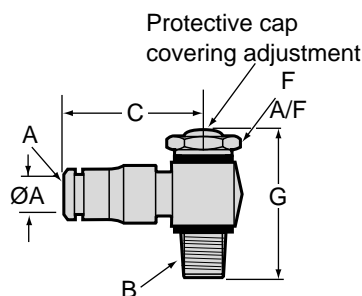

A Tube O.D.	B NPT or UNF Thread	Part Number	C	F A/F	G
5/32"	10-32 UNF	<b>12 VB0 0210</b>	0.74 (19)	-	1.06 (27)
	1/8	<b>12 VB0 0218</b>	0.88 (22)	9/16"	1.57 (40)
1/4"	1/8	<b>12 VB0 0418</b>	0.91 (23)	9/16"	1.57 (40)
	1/4	<b>12 VB0 0428</b>	0.99 (25)	3/4"	1.83 (46)
3/8"	1/4	<b>12 VB0 0628</b>	1.23 (31)	3/4"	1.83 (46)
	3/8	<b>12 VB0 0638</b>	1.29 (33)	7/8"	2.22 (56)
1/2"	3/8	<b>12 VB0 0738</b>	1.46 (37)	7/8"	2.22 (56)
	1/2	<b>12 VB0 0748</b>	1.56 (40)	11/16"	2.55 (65)

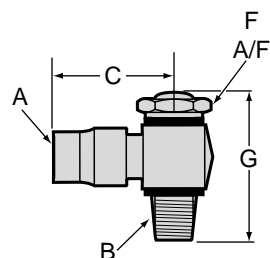

A NPT Female	B NPT Male	Part Number	C	F	G
1/8	1/8	<b>12 VB0 1818</b>	0.83 (21)	9/16"	1.57 (40)
1/4	1/4	<b>12 VB0 2828</b>	1.14 (29)	3/4"	1.83 (46)
3/8	3/8	<b>12 VB0 3838</b>	1.24 (31)	7/8"	2.22 (56)
1/2	1/2	<b>12 VB0 4848</b>	1.53 (39)	11/16"	2.55 (65)



# Function Fittings and Flow Controls

## TA0 Series

Dimensions in MM (inches)

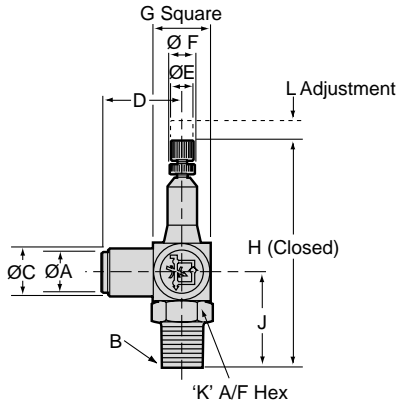

A Tube O.D.	B ISO R Thread	Part Number	C	D	E	F	G	H	J	K A/F	L Adj
4	1/8	10 TA0 0418	11.5 (.45)	22.0 (.87)	8.0 (.31)	9.0 (.35)	16 (.63)	53 (2.09)	22.5 (.89)	14 (.55)	3 (.12)
	1/8	10 TA0 0618	13.0 (.51)	23.0 (.91)	8.0 (.31)	9.0 (.35)	16 (.63)	53 (2.09)	22.5 (.89)	14 (.55)	3 (.12)
6	1/4	10 TA0 0628	13.5 (.53)	25.5 (1.00)	10.0 (.39)	11.0 (.43)	20 (.79)	67 (2.64)	29.5 (1.16)	17 (.67)	6 (.24)
	1/4	10 TA0 0828	15.5 (.61)	27.0 (1.06)	10.0 (.39)	11.0 (.43)	20 (.79)	67 (2.64)	29.5 (1.16)	17 (.67)	6 (.24)
8	3/8	10 TA0 0838	15.5 (.61)	28.0 (1.10)	12.0 (.47)	13.0 (.51)	22 (.87)	78 (3.07)	33.0 (1.30)	19 (.75)	6 (.24)
	1/4	10 TA0 1028	19.5 (.77)	31.5 (1.24)	10.0 (.39)	11.0 (.43)	20 (.79)	67 (2.64)	29.5 (1.16)	17 (.67)	6 (.24)
10	3/8	10 TA0 1038	19.5 (.77)	32.5 (1.28)	12.0 (.47)	13.0 (.51)	22 (.87)	78 (3.07)	33.0 (1.30)	19 (.75)	6 (.24)

## K51 Series

Dimensions in Inches (mm)

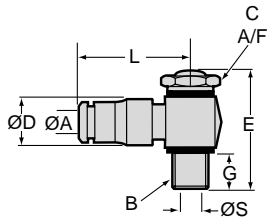

A Tube O.D.	B ISO G or Metric Thread	Part Number	C A/F	D	E	G	L	S
4	M5 X .8	10 K51 0405	8 (.31)	9.5 (.37)	26.5 (1.04)	4.0 (.16)	18.7 (.74)	2.5 (.10)
	1/8	10 K51 0418	14 (.55)	11.0 (.43)	34.0 (1.34)	6.5 (.26)	20.6 (.81)	5.0 (.20)
5	M5 X .8	10 K51 0505	8 (.31)	11.0 (.43)	26.5 (1.04)	4.0 (.16)	20.2 (.80)	2.5 (.10)
	1/8	10 K51 0518	14 (.55)	11.5 (.45)	34.0 (1.34)	6.5 (.26)	21.7 (.85)	5.0 (.20)
6	M5 X .8	10 K51 0605	8 (.31)	12.5 (.49)	26.5 (1.04)	4.0 (.16)	22.2 (.87)	2.5 (.10)
	1/8	10 K51 0618	14 (.55)	12.5 (.49)	34.0 (1.34)	6.5 (.26)	23.7 (.93)	5.0 (.20)
	1/4	10 K51 0628	17 (.67)	13.0 (.51)	36.5 (1.44)	7.0 (.28)	24.2 (.95)	8.5 (.33)
8	1/8	10 K51 0818	14 (.55)	13.5 (.53)	34.0 (1.34)	6.0 (.26)	23.7 (.93)	-
	1/4	10 K51 0828	17 (.67)	14.0 (.55)	36.5 (1.44)	7.0 (.28)	24.7 (.97)	8.5 (.33)
	3/8	10 K51 0838	22 (.87)	16.5 (.65)	51.5 (2.03)	10.0 (.39)	26.7 (1.05)	10.0 (.39)
10	3/8	10 K51 1038	22 (.87)	17.0 (.67)	51.5 (2.03)	10.0 (.39)	31.2 (1.23)	10.0 (.39)
12	1/2	10 K51 1248	27 (1.06)	17.5 (.69)	57.5 (2.26)	10.0 (.39)	38.2 (1.50)	-

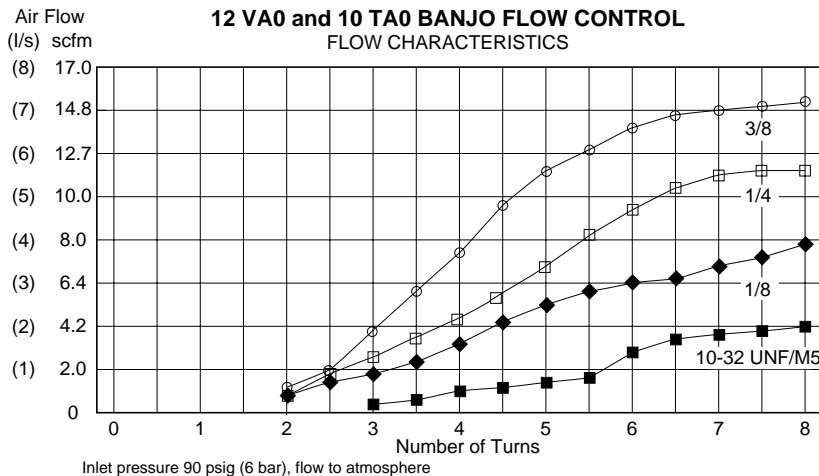

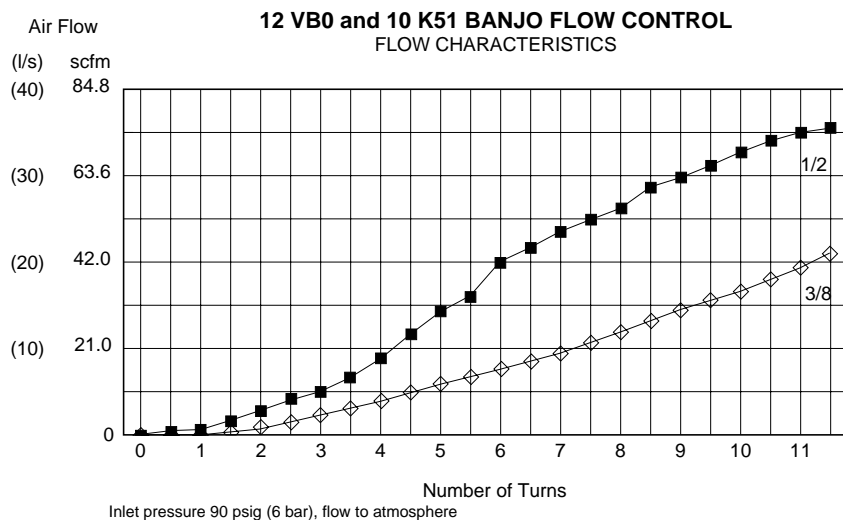
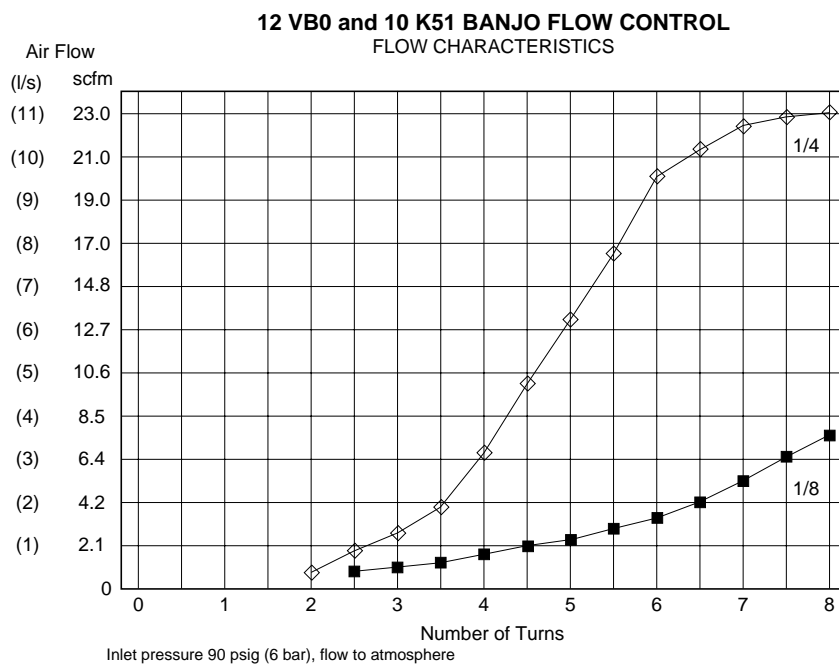
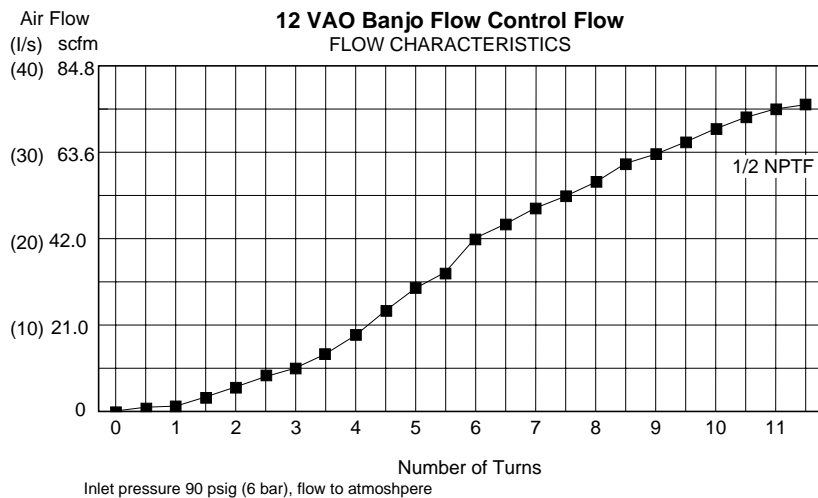

- Compact size/low weight/In-line units
- High Flow Performance
- Suitable for panel and wall mounting
- Provides linear flow adjustment
- Locking adjustment
- Captive adjustment needle will not blow out when unscrewed
- Index line on adjusting knob
- Available in 1/8, 1/4, 3/8, and 1/2 porting



### Technical Data

Fluid: Compressed air, nitrogen, inert and non-combustible gases compatible with materials of construction.

**Note:** For other types of fluids or compressed gases, please consult factory.

Operation:

Uni-directional flow control.

Mounting:

In-line. Panel mounted by hexagonal mounting nut. Wall mounted via through-holes in regulator body.

Port size: NPT

1/8	<b>T1000A1800</b>
1/4	<b>T1000A2800</b>
3/8	<b>T1000A3800</b>
1/2	<b>T1000A4800</b>

ISO G

<b>T1000C1800</b>
<b>T1000C2800</b>
<b>T1000C3800</b>
<b>T1000C4800</b>

Operating pressure:

15 to 145 psig (1-10 bar)

Operating Temperature:

0° to 175°F (-20° to 80°C)

Consult our technical service for use below 35°F (2°C)

Opening Pressure (N-R Valve)

15 psig (1 bar)

### Materials

1/8, 1/4: Aluminum alloy body, Nitrile seals, brass needle and internal parts, external parts in aluminum alloy.

3/8, 1/2: Aluminum alloy body, Nitrile seals, brass needle and internal parts, external parts in aluminum alloy.

### Ordering Information

To order, quote product number from table on page FIT-3-7: i.e. T1000A2800 for 1/4 NPT model.

Alternate Models:

T1000M0500 - M5

T1100C1800 - 1/8" Bi-directional ISO G

T1100A1800 - 1/8" Bi-directional NPT

T1100C2800 - 1/4" Bi-directional ISO G

T1100A2800 - 1/4" Bi-directional NPT

### ISO Symbol

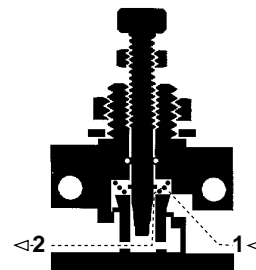
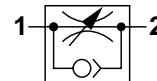



Model T1000A and T1000C

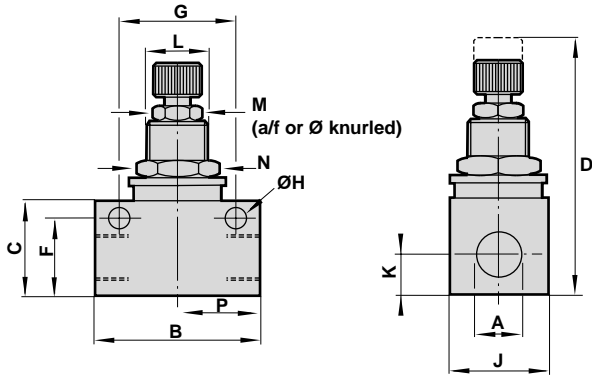

Model	Cv Regulating NPT port	Cv Free Flow NPT port	Weight grams oz. (g)
T1000A1800	0.14	0.37	1.1 (31)
T1000A2800	0.32	0.69	2.0 (56)
T1000A3800	1.00	1.45	5.3 (150)
T1000A4800	1.60	1.90	6.3(180)

Model	A	B	C	D	F	G	H	J	K	L	A/F M	N	P	PanelMax Hole	Panel Thickness
T1000A1800	1/8 NPT	1.33 (34.0)	0.79 (20.0)	2.0 (51.0)	0.65 (16.5)	0.94 (24.0)	0.18 (4.5)	0.63 (16.0)	0.38 (8.0)	M12 x 1 -	0.39 (Ø10.0)	0.55 (14.0)	0.67 (17.0)	0.49 (12.5)	0.16 (4.0)
T1000A2800	1/4 NPT	1.77 (45.0)	1.0 (25.4)	2.42 (61.5)	0.82 (20.8)	1.26 (32.0)	0.18 (4.5)	0.75 (19.0)	0.38 (9.7)	M14 x 1 -	0.39 (Ø10.0)	0.67 (17.0)	0.89 (22.5)	0.57 (14.5)	0.16 (4.0)
T1000A3800	3/8 NPT	2.28 (58.0)	1.28 (32.5)	3.09 (78.5)	1.06 (27.0)	1.69 (43.0)	0.26 (6.5)	1.10 (28.0)	0.51 (13.0)	M20 x 1 -	0.39(a/f) (14.0)	0.94 (24.0)	1.14 (29.0)	0.81 (20.5)	0.16 (4.0)
T1000A4800	1/2 NPT	2.56 (65.0)	1.42 (36.0)	3.23 (82.0)	1.20 (30.5)	1.97 (50.0)	0.26 (6.5)	1.18 (30.0)	0.29 (15.0)	M20 x 1 -	0.39 (a/f) (14.0)	0.94 (24.0)	1.28 (32.5)	0.81 (20.5)	0.16 (4.0)

NPT according to ANSI B 1.20.1

Flow vs Turns at 90 psi (6 bar)

T1000A1800

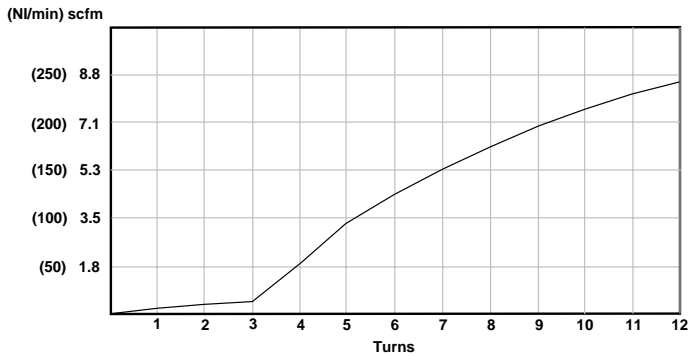

T1000A2800

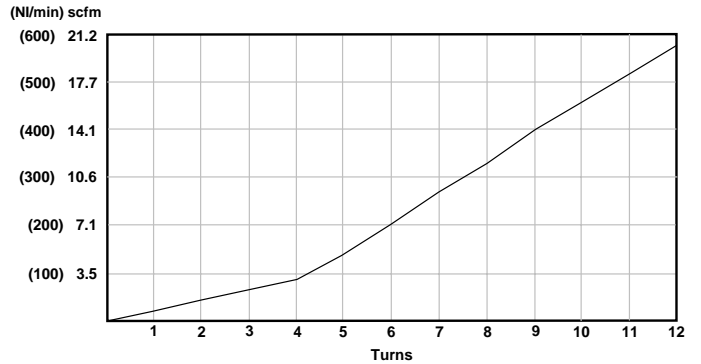

T1000A3800

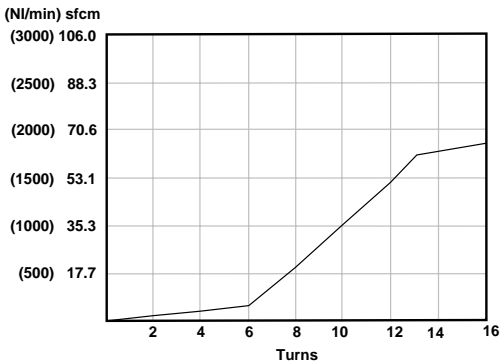

T1000A4800

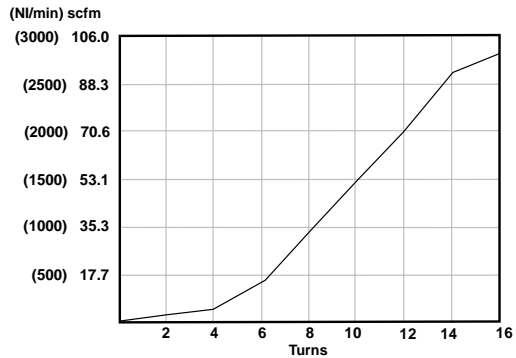

## Push-In Flow Regulators

T-15 Series

Ø 3, 4, 5, 6, 10, 12 mm O/D Tube

- High flow performance
- Suitable for panel/wall mounting and manifold
- Adjustment can be locked
- Captive regulator needle will not blow out when unscrewed
- Adjusting knob position
- Releasable grab ring technology combining plastic and brass components for a compact and superior fitting design
- Color coding option with tamper-resistant feature
- Red release sleeve indicating metric tube sizes
- Grey release sleeve indicating inch tube sizes
- Reliable and corrosion resistant



### Technical Data

Medium: Compressed Air, filtered

Operation: Uni-directional

Operating Pressure:

1.5 to 145 psig (0.1 to 10 bar)

Ambient Temperature:

0° to 175°F (-20°C\* to 80°C)

Consult our Technical Service for use below 35°F (2°C)

Mounting:

In-line. Panel mounted by hexagonal mounting nut. Wall mounted by through-holes in regulator body. Manifold by quick connection

### Alternative Models

Block form flow regulators, T1000 series

Heavy duty flow regulators, M/800, M/600

Precision flow regulators, M/650, M677 and S/790

### Materials

1/8" (3mm), 5/32" (4mm), 3/16" (5mm), 1/4" (6mm),

5/16" (8mm), 3/8" (10mm)

Body: plastic PBT

Seals: silicone free nitrile seal, external metal parts: nickel plated brass

Internal parts: brass

Spring: stainless steel

Grab ring: stainless steel, BS 1440 Pt 2, grade 301.S21

Knob and panel nut: plastic POM

3/16" (5mm), – 1/2" (12mm)

Collet: nickel plated brass

### Ordering Information

To order, quote model number from table on page FIT-3-9, e.g. T15Y0004 to order 1/4" model.

### ISO Symbol

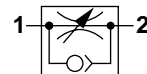



Push-In Flow Regulators

T-15

Metric Tube	Model	Inch Tube	Model	Maxi regulated flow factor C/Cv**	Free flow factor C/Cv**	oz (kg)
3 mm	T15P0003	1/8"	T15Y0001	0.07 (0.3)	0.07 (0.3)	.46 (0.013)
4 mm	T15P0004	5/32"	T15Y0002	0.11 (0.45)	0.11 (0.45)	.46 (0.013)
5 mm	T15P0005*	3/16"	T15Y0003*	0.21 (0.85)	0.21 (0.85)	1.13 (0.032)
6 mm	T15P0006	1/4"	T15Y0004	0.32 (1.3)	0.32 (1.3)	.99 (0.028)
8 mm	T15P0008	5/16"	T15Y0005	0.54 (2.2)	0.54 (2.2)	1.66 (0.047)
10 mm	T15P0010	3/8"	T15Y0006	0.71 (2.9)	0.78 (3.2)	3.28 (0.093)
12 mm	T15P0012*	1/2"	T15Y0007*	1.32 (5.4)	1.32 (5.4)	.50 (0.0143)

\* Available in collet system

\*\* C measured in dm<sup>3</sup>/(s.bar) Cv measured in US gal/min

T15

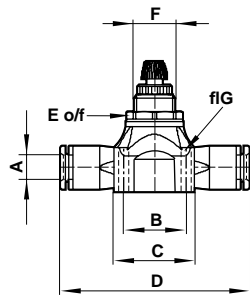

Metric	A	B	C	D	E	F	ØG
T15P0003	0.12 (3)	0.51 (13)	0.67 (17)	1.81 (46)	0.51 (13)	M10x1	0.09 (2)
T15P0004	0.16(4)	0.51 (13)	0.67 (17)	1.81 (46)	0.51 (13)	M10x1	0.09 (2)
T15P0005	0.20(5)	0.75 (19)	0.98 (25)	1.93 (49)	0.59 (15)	M12x1	0.14 (4)
T15P0006	0.24(6)	0.75 (19)	0.98 (25)	2.17 (55)	0.59 (15)	M12x1	0.14 (4)
T15P0008	0.31(8)	0.83 (21)	1.06 (27)	2.58 (66)	0.71 (18)	M14x1.5	0.14 (4)
T15P0010	0.39(10)	1.04 (27)	1.34 (34)	3.02 (77)	0.94 (24)	M20x1.5	0.17 (4)
T15P0012	0.47(12)	1.12 (29)	1.42 (36)	3.64 (93)	0.94 (24)	M20x1.5	0.17 (4)
Inch	A	B	C	D	E	F	ØG
T15Y0003	1/8	0.51 (13)	0.67 (17)	1.81 (46)	0.51 (13)	M10x1	0.09 (2)
T15Y0004	5/32	0.51 (13)	0.67 (17)	1.81 (46)	0.51 (13)	M10x1	0.09 (2)
T15Y0005	3/16	0.75 (19)	0.98 (25)	1.93 (49)	0.59 (15)	M12x1	0.14 (4)
T15Y0006	1/4	0.75 (19)	0.98 (25)	2.17 (55)	0.59 (15)	M12x1	0.14 (4)
T15Y0008	5/16	0.83 (21)	1.06 (27)	2.58 (66)	0.71 (18)	M14x1.5	0.14 (4)
T15Y0010	3/8	1.04 (27)	1.34 (34)	3.02 (77)	0.94 (24)	M20x1.5	0.17 (4)
T15Y0012	1/2	1.12 (29)	1.42 (36)	3.64 (93)	0.94 (24)	M20x1.5	0.17 (4)

Flow vs turns at 6 bar - flow in dm<sup>3</sup>/s ANR

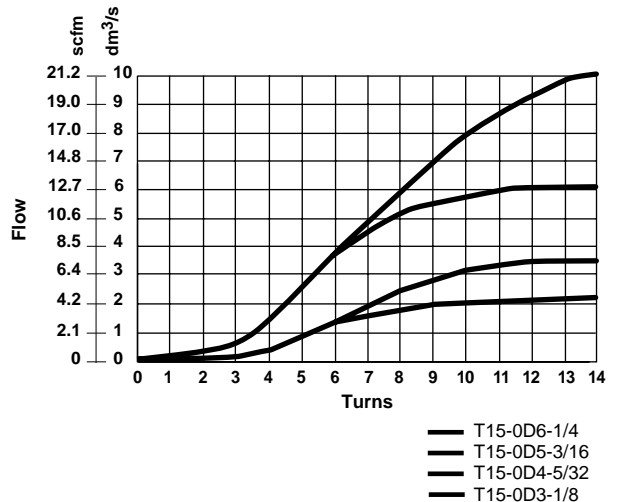
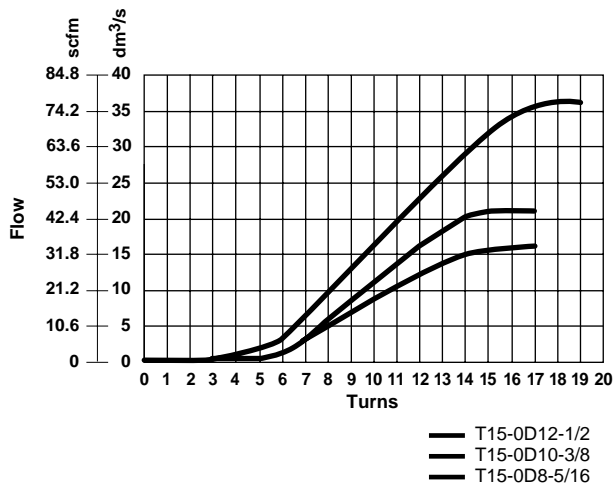

- In-line general purpose flow controls
- Captive adjustment needle will not blow out when unscrewed
- Lockable, calibrated adjustment knob
- Suitable for wall mounting
- High operating pressure



### Technical Data

Fluid: Compressed air, nitrogen, inert and non-combustible gases compatible with materials of construction.

**Note:** For other types of fluids or compressed gases, please consult factory.

Operation: Uni-directional

Mounting:

Line mounted, concentrically

Port Size:

	NPT		ISO G		Weight lbs. (Kg)
1/8 NPT	C/836	G1/8	S/836		.22 (.10)
1/4 NPT	C/837	G1/4	M/837		.33 (.15)
1/2 NPT	C/839	G1/2	M/839		1.32 (.60)
3/4 NPT	C/840	G3/4	M/840		2.65 (1.20)
1 NPT	C/855	G1	M/855		7.72 (3.50)

Operating Pressure:

5 - 230 psig (0.3 - 16 bar)

Operating Temperature:

0°\* to 175°F (-20° to +80°C) (Alternative models to 300°F [150°C])

\* Consult our Technical Service for use below 35°F (2°C.)

### Materials

Brass body, adjusting knob, and locking ring (C/836, C/837, C/839), aluminum body, adjusting knob and locking ring (C/840, C/855), nitrile rubber seals.

### Repair Kits

Product Number		Kit Number	
NPT	ISO G	NPT	ISO G
<b>C/836</b>	S/836	QC/520/00	QS/520/00
<b>C/837</b>	<b>M/837</b>	QC/521/00	QS/521/00
<b>C/839</b>	M/839	QC/822/00	QS/522/00
C/840	M/840	QC/523/00	QS/523/00
C/855	M/855	QC/524/00	QS/524/00

### Ordering Information

To order, quote model number from table on page FIT-3-11, e.g. C/837 for the 1/4" NPT model

### Alternative models

C/600 range of heavy duty panel mounting Flow Controls (air & hydraulic), see page FIT-3-12.

T1000 range of Inline Flow Controls, see page FIT-3-6.

TM, TC/800 High Temperature version (150° C max.)

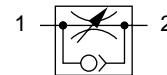

# Function Fittings and Flow Controls

Dimensions in Inches (mm)



## Flow Control

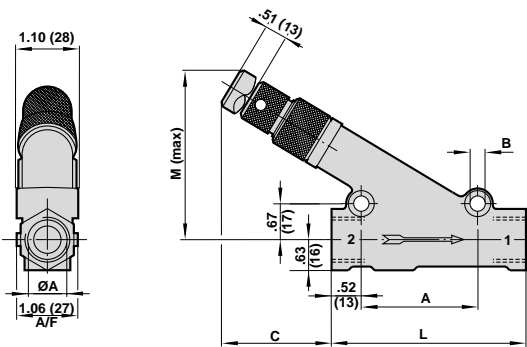

Thread	NPT	G	A	L	C	B	M (max)	D
1/8	<b>C/836</b>	S/836	.96 (25)	1.81 (46)	1.06 (27)	.33 (8)	3.11 (79)	.67 (17)
1/4	<b>C/837</b>	M/837	1.63 (42)	2.36 (60)	.98 (25)	.20 (5)	1.46 (37)	.87 (22)
1/2	<b>C/839</b>	M/839	2.25 (57)	3.7 (94)	2.09 (53)	.33 (8)	3.11 (79)	1.10 (28)
3/4	C/840	M/840	2.99 (76)	4.69 (119)	2.60 (66)	.34 (9)	4.09 (104)	1.38 (35)
1	C/855	M/855	3.54 (90)	5.90 (150)	4.22 (107)	.51 (13)	5.79 (147)	2.04 (52)

Typical Model Number: **C/839**  
M/839

ØA  
1/2 NPT  
G1/2

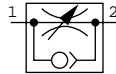

Type: Uni-directional  
Free flow is from '2' to '1', indicated by arrow

Port	Model		Max. Regulating	Max. Free
	NPT	ISO G	Flow Cv	Flow Cv
1/8	<b>C/836</b>	S/836	0.17	0.6
1/4	<b>C/837</b>	M/837	0.49	1.0
1/2	<b>C/839</b>	M/839	2.6	3.6
3/4	C/840	M/840	3.7	6.5
1	C/855	M/855	8.4	8.9

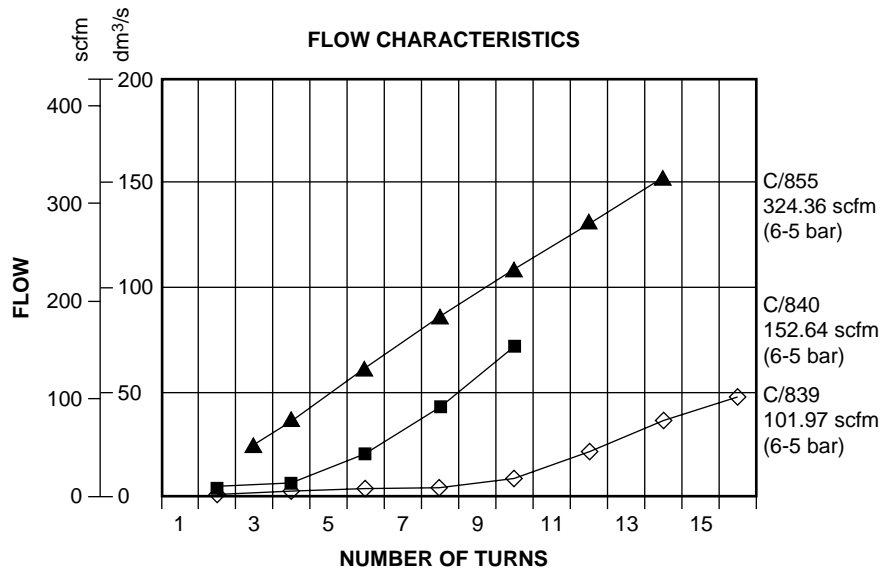
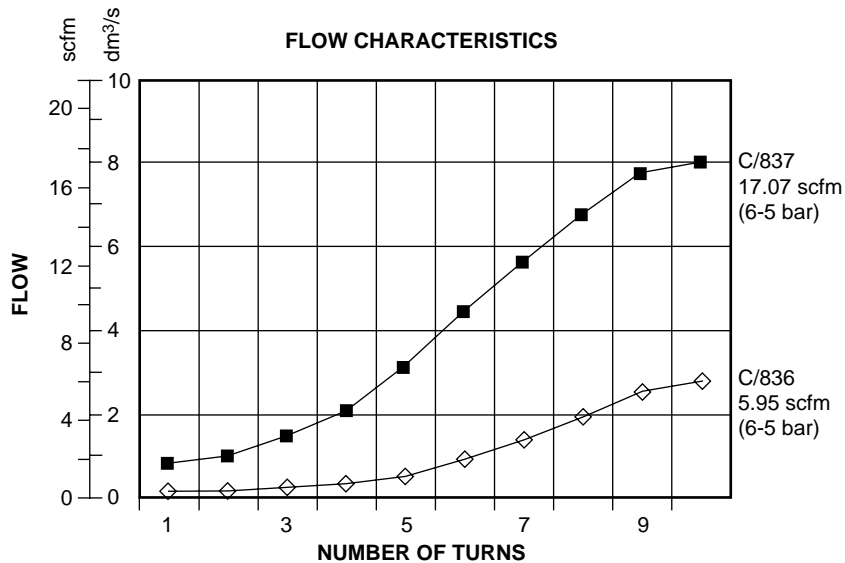

- Panel mounted general purpose flow controls
- Captive adjustment needle will not blow out when unscrewed
- Calibrated adjusting knob, can be locked on 1/8 and 1/2 models
- Panel mount legend plate indicating direction of flow control supplied as standard
- High operating pressure

### Technical Data

Fluid: Compressed air, nitrogen, inert and non-combustible gases compatible with materials of construction.

**Note:** For other types of fluids or compressed gases, please consult factory.

Operation:

Uni-directional

Mounting:

Panel mounted

Port Sizes:

	NPT	ISO G	Weight lbs. (Kg)
1/8 NPT	C/636	G1/8 S/636	.29 (.13)
1/4 NPT	C/637	G1/4 M/637	.49 (.22)
1/2 NPT	C/639	G1/2 M/639	1.72 (.78)

Operating Pressure:

5 - 230 psig (0.3 - 16 bar)

Operating Temperature:

0°\* to 175°F (-20° to 80°C)

\*Consult our Technical Service for use below 35°F (2°C)

### Flow

Product	Port Size	Cv Max Reg Flow	Cv Max Free Flow
C/636	1/8"	0.17	0.51
C/637	1/4"	0.49	1.05
C/639	1/2"	2.94	4.16

### Materials

Brass body, chromium plated adjusting knob, locking ring and panel mounting ring, nitrile rubber seals.

### Spares Kits

Product Number		Kit Number	
NPT	ISO G	NPT	ISO G
C/636	S/636	QC/520/00	QS/520/00
C/637	M/637	QC/521/00	QS/521/00
C/639	M/639	QC/522/00	QS/522/00



### Ordering Information

To order, quote model number from table on page FIT-3-12, e.g. C/637 for the 1/4" model

Alternative models

C/800 range of Heavy duty flow controls, see page FIT-3-10.

T1000 range of In-Line Flow Controls, see page FIT-3-6.

TM, TC/800 high temperature version 300°F (150°C) max.

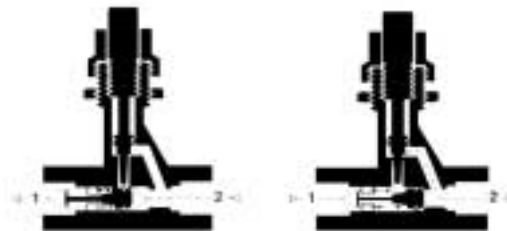
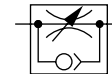



- Allow free flow in one direction only
- Low cracking pressure
- PIF-PIF, PIF-Male and Male-PIF alternatives
- Non-PTFE based thread sealant on taper threads
- Releasable grab ring technology combining plastic and brass components for a compact and superior fitting design
- Molded mounting brackets on tub connector designs
- Low weight design
- Red release sleeve indicating metric tube sizes
- Grey release sleeve indicating inch tube sizes
- Easy tube insertion for rapid and quick assembly of pneumatic circuits
- Reliable and corrosion resistant
- Silicon free
- Color coding option with tamper-resistant feature



#### Technical Data

Medium: Compressed Air, filtered, lubricated or non-lubricated, vacuum

Operating Pressure:

- 1.5 to 145 psig (0.1 to 10 bar) (T51, T52)
- 4.4 to 145 psig (0.3 to 10 bar) (T53)
- 1.5 to -14.5 psig (-0.1 to -1 bar) vacuum (T51, T52)

Ambient Temperature:

- 0° to 175°F (-20°C\* to 80°C)
- Consult our Technical Service for use below 35°F (2°C)

Mounting:

- Tube/tube PIF
- Tube PIF/male thread
- Male threaded/tube PIF

#### Alternative Models

T55, T56 range of aluminum threaded non return valves.  
TS/520 range of brass threaded non return valve.

#### Materials

##### OD 4-0D8

Body: Plastic PBT  
Seal: Silicon free nitrile  
Valve: Plastic PBT  
Insert: Natural brass  
Spring: Stainless steel  
Grab Ring: Stainless steel - BS 1440  
PT 2, grade 301.S21 (4-6-8 sizes)

##### OD-5 collet system

T-52 and T-53 series, nickel brass threads.

##### OD 10 - OD12 sizes

Collet: Nickel plated brass  
Body: Black anodized aluminum  
Valve and Insert: Aluminum

#### Ordering Information

To order, quote model number from table on page FIT-3-15, e.g. T51Y0004 for the 1/4" model.

NOTE: T51 and T52 flow is threaded end to push-in (check is in reverse).

T53 flow is from push-in to threaded end (check is in reverse).

#### ISO Symbol

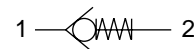



## Inline Push-in Non Return Valves

T-51, T-52 and T-53 Series. Operating pressure: 10 bar (14 psi)

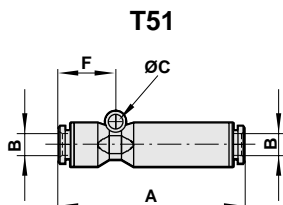

Inch PIF/PIF	Model #	Metric PIF/PIF	Model #
5/32"	T51Y0002	4	T51P0004
3/16"	T51Y0003*	5	T51P0005*
1/4"	T51Y0004	6	T51P0006
5/16"	T51Y0005	8	T51P0008
3/8"	T51Y0006*	10	T51P0010*
1/2"	T51Y0007*	12	T51P0012*

\* Available only with collet tube connection

Inch Model	A	B	F	ØC
T51Y0002	49.8	5/32	15.5	4.3
T51Y0003*	53.1	3/16	15.2	4.3
T51Y0004	55.3	1/4	16.9	4.3
T51Y0005	62.5	5/16	19.0	4.3
T51Y0006*	77.4	3/8	-	-
T51Y0007*	88.4	1/2	-	-

Metric Model	A	B	F	ØC
T51P0004	48.8	4	15.5	4.3
T51P0005*	53.1	5	15.2	4.3
T51P0006	55.3	6	16.9	4.3
T51P0008	62.5	8	19.0	4.3
T51P0010*	77.4	10	-	-
T51P0012*	88.4	12	-	-

## T52, T53

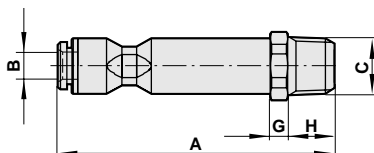

Inch PIF/Male Thrd.	Model #	Metric PIF/ISO Rc	Model #
5/32" x 1/8"	T52A1802	4 x M5	T52M0504
3/16" x 1/8"	T52A1803*	4 x 1/8"	T52B1804
3/16" x 1/4"	T52A2803*	5 x 1/8"	T52B1805*
1/4" x 1/8"	T52A1804	5 x 1/4"	T52B2805*
1/4" x 1/4"	T52A2804	6 x 1/8"	T52B1806
5/16" x 1/8"	T52A1805*	6 x 1/4"	T52B2806
5/16" x 1/4"	T52A2805	8 x 1/8"	T52B1808
		8 x 1/4"	T52B2808

Inch Male Thrd./PIF	Model #	Metric ISO Rc/PIF	Model #
1/8 x 5/32"	T53A1802	M5 x 4	T53M0504
1/8 x 3/16"	T53A1803*	1/8 x 4	T53B1804
1/4 x 3/16"	T53A2803*	1/8 x 5	T53B1805*
1/8 x 1/4"	T53A1804	1/4 x 5	T53B2805*
1/4 x 1/4"	T53A2804	1/8 x 6	T53B1806
1/8 x 5/16"	T53A1805	1/4 x 6	T53B2806
1/4 x 5/16"	T53A2805	1/8 x 8	T53B1808
		1/4 x 8	T53B2808

Inch Model	A	B	C**	G	H
T52A1802	54.4	5/32	1/8	4	9.5
T52A1803*	57.9	3/16	1/8	4	9.5
T52A2803*	62.7	3/16	1/4	4	14.3
T52A1804	59.2	1/4	1/8	4	9.5
T52A2804	64	1/4	1/4	4	14.3
T52A1805	63.7	1/8	1/8	4	9.5
T52A2805	68.5	1/4	1/4	4	14.3

\*\* NPTF

Metric Model	A	B	C**	G	H
T52M0504	49.2	4	M5	4	4.3
T52B1804	54.4	4	1/8	4	9.5
T52B1805*	57.9	5	1/8	4	9.5
T52B2805*	59.4	5	1/4	4	11
T52B1806	59.2	6	1/8	4	9.5
T52B2806	60.7	6	1/4	4	11
T52B1808	63.7	8	1/8	4	9.5
T52B2808	65.2	8	1/4	4	11

\*\* BSPT

## Non-Return Valves T55, T56 Series

In-Line, Non-Return Valves  
M5, 1/8", 1/4", 3/8, 1/2" ISO G, ISO R, NPT

- Permits free flow of air in one direction only
- Simple, reliable design
- Light weight
- Silicone free
- Low cracking pressure
- T56 male connections have an O-ring in parallel threads



### Technical Data

#### Medium:

Compressed air, filtered, lubricated and non-lubricated

#### Operation:

Non-return valve

#### Mounting:

Line mounted

#### Port Sizes:

Metric	ISO G	ISO Rc	NPT
M5 T55M0500	G1/8 T55C1800	Rc1/8 T55B1800	1/8 NPT <b>T55A1800</b>
	G1/4 T55C2800	Rc1/4 T55B2800	1/4 NPT <b>T55A2800</b>
	G3/8 T55C3800	Rc3/8 T55B3800	3/8 NPT <b>T55A3800</b>
	G1/2 T55C4800	Rc1/2 T55B4800	1/2 NPT <b>T55A4800</b>
	G3/4 TS/523		3/4 NPT <b>TC/523</b>
	G1 TS/524		1 NPT <b>TC/524</b>

\*High temperature viton seals

#### Operating Pressure:

1.5 - 145 psi (0.1 - 10 bar)

5 - 230 psi (0.3 - 16 bar)

#### Operating Temperature:

0°\* to 300°F (-20°\* to +150°C)

\*Consult our Technical Service for use below 35°F (2°C). For high temperature applications (300°F [150°C] Max) TM, TC/520 Series version should be ordered

### Materials

T55: Aluminum body (T55), brass (T56), silicone free nitrile rubber 'O' ring, POM valve, stainless steel spring.

TC/TS: Brass body, aluminum valve

High temp viton seals

### Ordering Information

To order, quote model number from table on page FIT-3-17, e.g. C/521 for the 1/4 NPT model

### Alternative Models

T51 Series in-line push-in non-return valves, see page FIT-3-14

### ISO Symbol

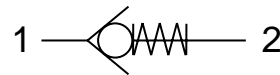



**T55 Series**

Port Size	Flow Factor Cv**	Flow Factor C*	Cracking pressure (bar)	oz (kg)	Model Metric	BSPB	BSPT	NPT
M5	0.19	0.8	0.73 (0.05)	0.35 (0.010)		T55M0500	T55B1800	T55A1800
1/8	0.59	2.4	0.73 (0.05)	0.53 (0.015)		T55C1800	T55B2800	T55A2800
1/4	1.35	5.5	0.73 (0.05)	0.88 (0.025)		T55C2800	T55B3800	T55A3800
3/8	2.20	9.0	0.73 (0.05)	2.12 (0.060)		T55C3800	T55B4800	T55A4800
1/2	3.70	15.0	0.73 (0.05)	2.82 (0.080)		T55C4800		

\* C measured in dm<sup>3</sup>/(s.bar) \*\* Cv measured in US gal/min.

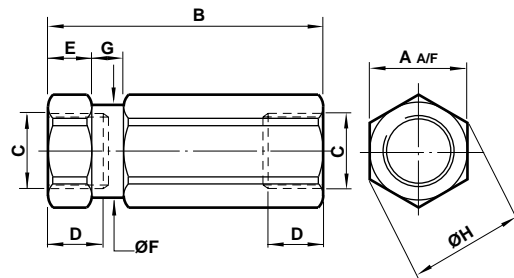

Model	A	B	C	D	E	F	G	H
T55M0500	.43 (11)	1.08 (27.5)	(M5)	.20 (5)	.16 (4)	.42 (10.7)	.12 (3)	.47 (12)
T55A1800	.55 (14)	1.67 (42.5)	(1/8)	-	.28 (7)	.54 (13.7)	.16 (4)	.59 (15)
T55B1800	.55 (14)	1.67 (42.5)	(1/8)	-	.28 (7)	.54 (13.7)	.16 (4)	.59 (15)
T55C1800	.55 (14)	1.67 (42.5)	(1/8)	.28 (7)	.28 (7)	.54 (13.7)	.16 (4)	.59 (15)
T55A2800	.67 (17)	2.13 (54)	(1/4)	-	.31 (8)	.66 (16.7)	.20 (5)	.73 (18.5)
T55B2800	.67 (17)	2.13 (54)	(1/4)	-	.31 (8)	.66 (16.7)	.20 (5)	.73 (18.5)
T55C2800	.67 (17)	2.13 (54)	(1/4)	.41 (10.5)	.31 (8)	.66 (16.7)	.20 (5)	.73 (18.5)
T55A3800	.94 (24)	2.48 (63)	(3/8)	-	.35 (9)	.93 (23.7)	.28 (7)	1.02 (26)
T55B3800	.94 (24)	2.48 (63)	(3/8)	-	.35 (9)	.93 (23.7)	.28 (7)	1.02 (26)
T55C3800	.94 (24)	2.48 (63)	(3/8)	.47 (12)	.35 (9)	.93 (23.7)	.28 (7)	1.02 (26)
T55A4800	1.06 (27)	3.03 (77)	(1/2)	-	.47 (12)	1.05 (26.7)	.39 (10)	1.18 (30)
T55B4800	1.06 (27)	3.03 (77)	(1/2)	-	.47 (12)	1.05 (26.7)	.39 (10)	1.18 (30)
T55C4800	1.06 (27)	3.03 (77)	(1/2)	.59 (15)	.47 (12)	1.05 (26.7)	.39 (10)	1.18 (30)

\* Available only with collet tube connection

**T56 Series**

Port Size	Flow Factor Cv**	Flow Factor C*	Cracking pressure (bar)	oz (kg)	Model Metric	BSPB	BSPT	NPT
M5	0.19	0.55	0.73 (0.05)	0.64 (0.018)	T56M0500			
1/8	0.59	2.4	0.73 (0.05)	1.59 (0.045)		T56C1800	T56B1800	T56A1800
1/4	1.23	5.0	0.73 (0.05)	2.82 (0.080)		T56C2800	T56B2800	T56A2800

\* C measured in dm<sup>3</sup>/(s.bar) \*\* Cv measured in US gal/min.

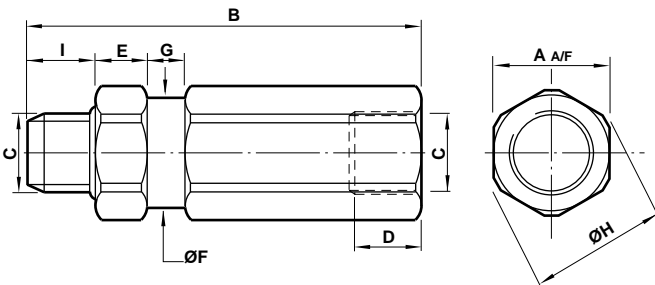

Model	A	B	C	D	F	G	H	I
T56M0500	.43 (11)	1.25 (31.8)	(M5)	.20 (5)	.42 (10.7)	.12 (3)	.47 (12)	.17 (4.3)
T56A1800	.55 (14)	1.93 (49)	(1/8)	(-)	.54 (13.7)	.16 (4)	.59 (15)	.37 (9.5)
T56B1800	.55 (14)	1.93 (49)	(1/8)	(-)	.54 (13.7)	.16 (4)	.59 (15)	.37 (9.5)
T56C1800	.55 (14)	1.77 (45)	(1/8)	.28 (7)	.54 (13.7)	.16 (4)	.59 (15)	.22 (5.5)
T56A2800	.67 (17)	2.46 (62.5)	(1/4)	(-)	.66 (16.7)	.20 (5)	.73 (18.5)	.56 (14.3)
T56B2800	.67 (17)	2.32 (59)	(1/4)	(-)	.66 (16.7)	.20 (5)	.73 (18.5)	.43 (11)
T56C2800	.67 (17)	2.21 (56.2)	(1/4)	.41 (10.5)	.66 (16.7)	.20 (5)	.73 (18.5)	.31 (8)

- Assists in complying with OSHA and related safety regulations
- Tamper proof
- Compact
- Low pressure drop
- Automatically resets after failure correction
- High air pressure rating



### Technical Data

Fluid: Compressed air, nitrogen, inert and non-combustible gases compatible with materials of construction.

**Note:** For other types of fluids or compressed gases, please consult factory.

#### Operation:

Fixed uni-directional excess flow automatic shut off valve (air fuse)

#### Mounting:

In-line two way valve

To be inserted between fixed air supply and flexible air lines

See guidelines for typical installation

#### Port Size: Female Thread

NPT		ISO G	
1/4 NPT	<b>T60A289*</b>	G 1/4	T60C289*
3/8 NPT	<b>T60A389*</b>	G 3/8	T60C389*
1/2 NPT	<b>T60A489*</b>	G 1/2	T60C489*
3/4 NPT	<b>T60A689*</b>	G 3/4	T60C689*
1 NPT	<b>T60A889*</b>	G 1	T60C889*
1-1/2 NPT	<b>T60A889*</b>	G 1-1/2	T60CB89*

\* Last digit depends on flow range

#### Operating Pressure:

Maximum 232 psi (16 bar)

Minimum according to hose length

Drop pressure at shut-off flow: 2 to 4.5 psi (0.14 or 0.3 bar)

#### Operating Temperature:

0<sup>\*\*\*</sup> to 175° F (-20° to 80°C)

**\*\***Consult our Technical Service for use below 35°F (2°C)

At low temperature ensure air fuse is not subjected to freezing conditions which may prevent its function.

### Materials

Aluminium body, brass internal parts, stainless steel spring

### Ordering Information

To order, quote appropriate product number from the tables on the following pages. i.e. T60A2890 for the 1/4 NPT with 2 psi pressure drop at shut off.

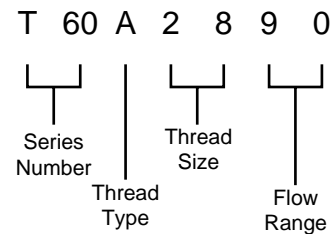

### Simplified Symbol

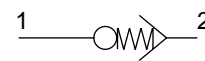

### ISO Symbol

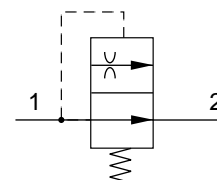



## General Information

Model		Port size	Drop pressure at shut off flow		Shut off flow rate at		Flow at 100 psi (7 bar) ΔP 1 psi (0.07 bar)		Weight	
NPT	ISO G		psi	(bar)	100 psi	(7 bar)	scfm	(dm³/s)	oz.	(Kg)
<b>T60A2890</b>	T60C2890	1/4	2.0	(.14)	17.6	(8)	13.8	(7)	1.4	(.04)
<b>T60A2891</b>	T60C2891		4.4	(.3)	29.7	(14)	13.8	(7)	1.4	(.04)
<b>T60A3890</b>	T60C3890	3/8	2.0	(.14)	41.1	(19)	28.6	(14)	2.3	(.07)
<b>T60A3891</b>	T60C3891		4.4	(.3)	68.2	(32)	28.6	(14)	2.3	(.07)
<b>T60A4890</b>	T60C4890	1/2	2.0	(.14)	68.2	(32)	49.2	(23)	5.3	(.15)
<b>T60A4891</b>	T60C4891		4.4	(.3)	102.3	(48)	49.2	(23)	5.3	(.15)
<b>T60A6890</b>	T60C6890	3/4	2.0	(.14)	102.3	(48)	91.1	(43)	4.6	(.13)
<b>T60A6891</b>	T60C6891		4.4	(.3)	169.5	(80)	91.1	(43)	4.6	(.13)
<b>T60A8890</b>	T60C8890	1	2.0	(.14)	195.0	(92)	144	(68)	19.0	(.54)
<b>T60A8891</b>	T60C8891		4.4	(.3)	271.0	(128)	144	(68)	19.0	(.54)
<b>T60AB890</b>	T60CB890	1-1/2	2.0	(.14)	394.0	(186)	307	(145)	38.8	(1)
<b>T60AB891</b>	T60CB891		4.4	(.3)	568.0	(268)	307	(145)	38.8	(1)

NPT : according to ANSI-B1.20.1.  
ISO G : according to BS2779 and ISO-228/1

Flow and pressure test conducted according to ISO-6358 test circuit. Mean measured flow values are provided at standard reference conditions.

## Air Fuse (Excess Flow Check)

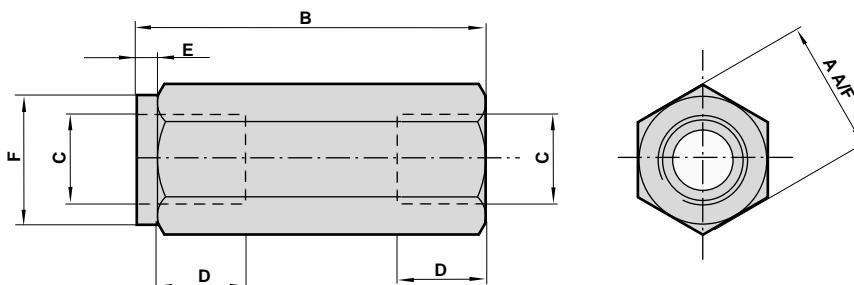

Model	T60A289*	T60C289*	T60A389*	T60C389*	T60A489*	T60C489*	T60A689*	T60C689*	T60A889*	T60C889*	T60AB89*	T60CB89*
	NPT	ISO G	NPT	ISO G	NPT	ISO G	NPT	ISO G	NPT	ISO G	NPT	ISO G
A	0.81 (21)	0.81 (21)	0.94 (24)	0.94 (24)	1.25 (32)	1.25 (32)	1.25 (32)	1.25 (32)	2.00 (51)	2.00 (51)	2.50 (64)	2.50 (64)
B	2.01 (51)	2.01 (51)	2.44 (62)	2.44 (62)	3.07 (78)	3.07 (78)	3.54 (90)	3.54 (90)	4.65 (118)	4.65 (118)	5.71 (145)	5.71 (145)
C	1/4	1/4	3/8	3/8	1/2	1/2	3/4	3/4	1.0	1.0	1.5	1.5
D	0.39 (10)	0.43 (11)	0.41 (10)	0.55 (14)	0.59 (15)	0.54 (14)	0.56 (14)	0.75 (19)	0.66 (17)	1.00 (26)	0.68 (17)	1.00 (26)
E	0.12 (3)	0.12 (3)	0.20 (5)	0.20 (5)	0.20 (5)	0.20 (5)	0.20 (5)	0.20 (5)	0.20 (5)	0.20 (5)	0.20 (5)	0.20 (5)
F	0.81 (21)	0.81 (21)	0.94 (24)	0.94 (24)	1.25 (32)	1.25 (32)	1.25 (32)	1.25 (32)	2.00 (51)	2.00 (51)	2.50 (64)	2.50 (64)



## Guidelines for Typical Installation

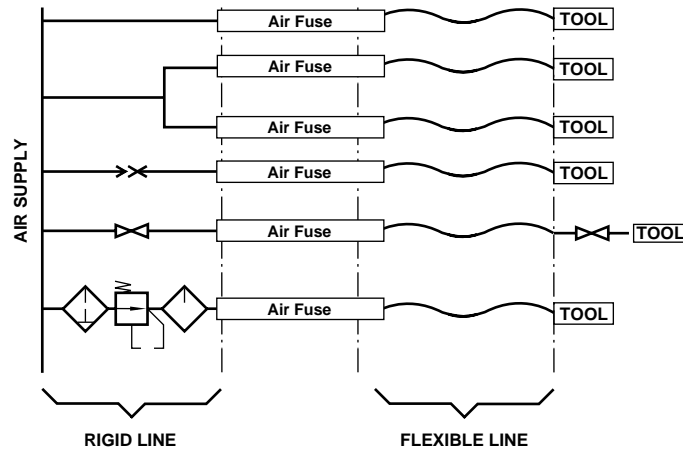

The air fuse should be installed directly between fixed or rigid pipework and the flexible tube to protect the whole length of the flexible tube. Only tubing **after** the air fuse is protected. The air fuse must be installed in the correct orientation. Failure to do this will render it ineffective. When a shut off valve is located before the air fuse, the valve must be opened slowly in order to control initial air flow and avoid decompression effects which may trip the air fuse.

It should be noted that the OSHA standard (29 CFR ChXVII Para 1926.302-b7) relating to pneumatic power tools states "All hoses exceeding 1/2" inside diameter shall have a safety device at the source of supply or branch line to reduce pressure in the case of hose failure."

### Choosing an Air Fuse\*

- The port size of the air fuse should be nominally equal to that of the supply lines - e.g. a 1/2 (12.7 mm) air fuse should be used with a 1/2" (12.7mm) ID hose.
- Always select the high flow model (91) if there is sufficient system pressure for the length of hose to be protected. See tables hose length vs. minimum supply pressure.
- If there is insufficient system pressure, or long hose lengths are to be protected, use model 90.
- After installation always test each valve for proper function. See section below on how to check an air fuse.
- The pneumatic system must be capable of delivering the flow required to activate the air fuse. For this reason, the air fuse is not suitable for use with the Norgren R07 miniature range in certain installations.
- For use with spring coils consult table. See table flow vs. pressure supply.

### Verifying Operation of an air fuse

- Install the air fuse following the instructions supplied
- Connect tool or complete circuit to the air line
- Switch on operation to ensure a complete cycle is performed
- If tool or complete circuit starts and runs satisfactorily, stop operation and drain air line. Disconnect hose from tool or circuit and secure hose end. Turn on air supply progressively (to avoid decompression effect). Prior to fully reaching operation conditions, the air fuse should suddenly activate and cut off the flow. A slight air flow will remain as part of the automatic re-set function. If the air fuse is not activated the unit should be disconnected and the lower flow range air fuse should be used.

\* Consult factory for the availability of Excel™ based sizing program.



**Hose length vs minimum pressure supply (1/4 to 3/8)**

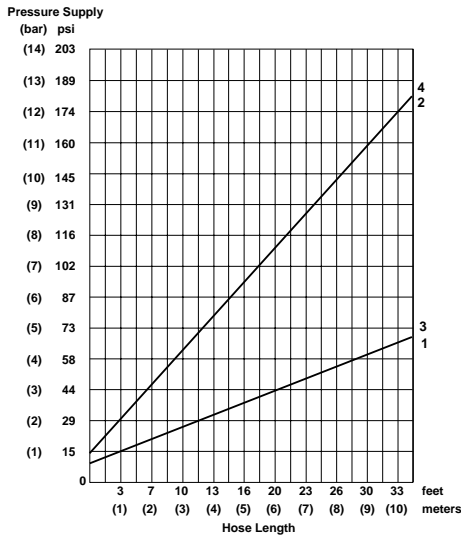

**KEY**

- 1 - T60 \* 2890 ID = 0.30" (7.5mm)
- 2 - T60 \* 2891 ID = 0.30" (7.5mm)
- 3 - T60 \* 3890 ID = 0.35" (9.0mm)
- 4 - T60 \* 3891 ID = 0.35" (9.0mm)

**Hose length vs minimum pressure supply (1/2 to 3/4)**

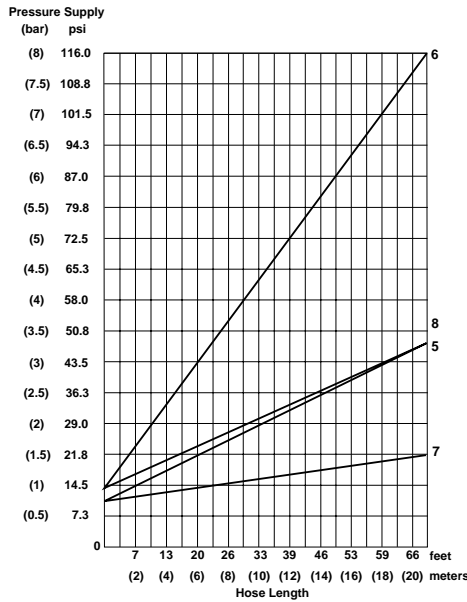

**KEY**

- 5 - T60 \* 4890 ID = 0.51" (13mm)
- 6 - T60 \* 4891 ID = 0.51" (13mm)
- 7 - T60 \* 6890 ID = 0.75" (19mm)
- 8 - T60 \* 6891 ID = 0.75" (19mm)

**Hose length vs pressure supply (1 to 1-1/2)**

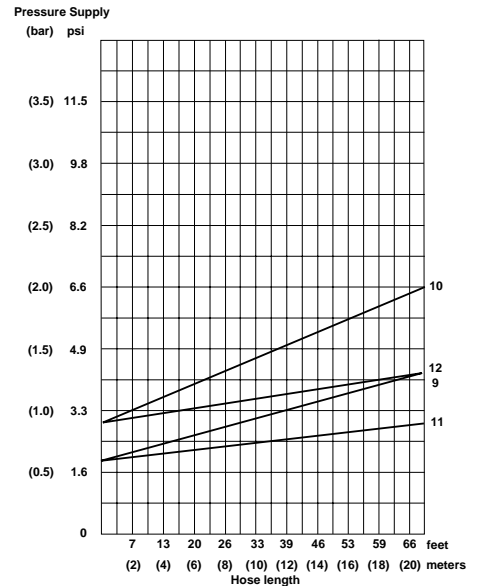

**KEY**

- 9 - T60 \* 8890 ID = 1.00" (25.0mm)
- 10 - T60 \* 8891 ID = 1.00" (25.4mm)
- 11 - T60 \* B890 ID = 1.50" (38.1mm)
- 12 - T60 \* B891 ID = 1.50" (38.1mm)

**Flow (±10%) vs pressure supply (1/4 to 1/2)**

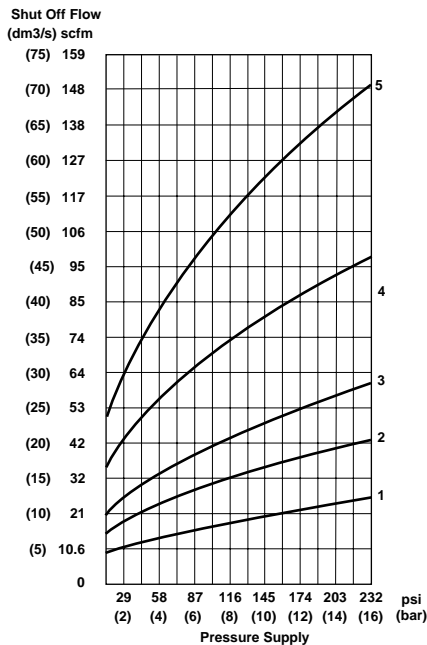

**KEY**

- 1 - T60 \* 2890
- 2 - T60 \* 2891
- 3 - T60 \* 3890
- 4 - T60 \* 3891
- 5 - T60 \* 4891

**Flow (±10%) vs pressure supply (3/4 to 1-1/2)**

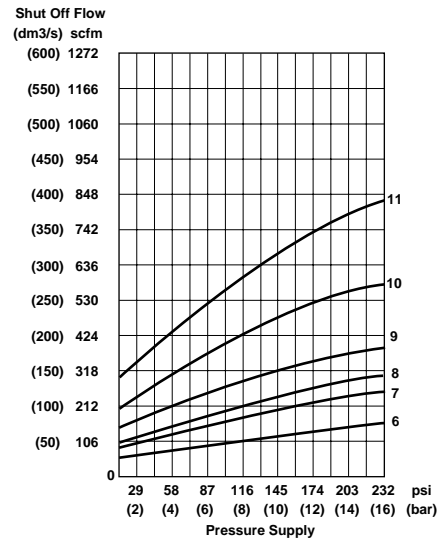

**KEY**

- 6 - T60 \* 6890
- 7 - T60 \* 6891
- 8 - T60 \* 8890
- 9 - T60 \* 8891
- 10 - T60 \* B890
- 11 - T60 \* B891

**Measurements**

- Flow and pressure tests conducted according to ISO-6358 test circuit
- Mean measured flow values are provided at standard reference condition 68°F, 15 psi, (20°C, 1.01 bar)
- Indicated pressure values are relative pressure in bar.

**Hose Lengths**

- Graphs are for indicated hose internal diameter in key.
- Consult our Technical Service for hose lengths and Internal diameters different from the recommended one.



## Function Fittings and Flow Controls

### Coiled hose selection table

Selection procedure for coiled hose:

Chose the thread size of your hose, the hose internal diameter in inches and the hose length in feet. The minimum supply pressure in psi is shown in the table below and the appropriate air fuse is shown in the left column. The “\*” in the middle of the part number represents the thread type - put an “A” for NPT and a “C” for ISO G threads. If no value is shown, it may not be possible to protect your hose with an air fuse. If in doubt, consult a Norgren distributor or Norgren.

Valve Model	Thread Size	Hose length Feet	Internal Hose Diameter (inch)												
			0.125	0.188	0.215	0.250	0.313	0.370	0.470	0.500	0.590	0.750	1.000	1.250	1.500
T60*2890	1/4	12		124	64	29	16	11	8	8	8	7	7	7	7
T60*2890	1/4	25			126	52	25	14	9	9	8	7	7	7	7
T60*2890	1/4	50			244	97	42	21	11	10	8	8	7	7	7
T60*2890	1/4	100				187	76	35	15	13	10	8	7	7	7
T60*2891	1/4	12				70	31	17	10	9	8	7	7	7	7
T60*2891	1/4	25				137	57	27	13	11	9	8	7	7	7
T60*2891	1/4	50					107	47	19	15	11	8	7	7	7
T60*2891	1/4	100					207	87	30	23	14	9	8	7	7
T60*3890	3/8	12				125	52	25	12	11	9	8	7	7	7
T60*3890	3/8	25					102	45	18	15	10	8	7	7	7
T60*3890	3/8	50					196	82	29	22	14	9	8	7	7
T60*3890	3/8	100						157	50	38	20	11	8	7	7
T60*3891	3/8	12						132	57	21	17	11	8	7	7
T60*3891	3/8	25							111	37	28	16	10	8	7
T60*3891	3/8	50							215	67	49	25	12	8	7
T60*3891	3/8	100								126	91	42	17	9	7
T60*4890	1/2	12						132	57	21	17	11	8	7	7
T60*4890	1/2	25							111	37	28	16	10	8	7
T60*4890	1/2	50							215	67	49	25	12	8	7
T60*4890	1/2	100								126	91	42	17	9	7
T60*4891	1/2	12							119	39	30	17	10	8	7
T60*4891	1/2	25								74	54	27	13	8	7
T60*4891	1/2	50								141	102	46	18	10	8
T60*4891	1/2	100									196	85	29	12	8
T60*6890	3/4	12							119	39	30	17	10	8	7
T60*6890	3/4	25								74	54	27	13	8	7
T60*6890	3/4	50								141	102	46	18	10	8
T60*6890	3/4	100									196	85	29	12	8
T60*6891	3/4	12								96	70	33	15	9	7
T60*6891	3/4	25								193	139	62	23	11	8
T60*6891	3/4	50										116	38	14	8
T60*6891	3/4	100										224	69	20	9
T60*8890	1	12								123	89	41	17	9	7
T60*8890	1	25									178	78	27	12	8
T60*8890	1	50										148	47	16	8
T60*8890	1	100											88	24	9
T60*8891	1	12								231	166	73	26	11	8
T60*8891	1	25										144	46	16	8
T60*8891	1	50											85	24	9
T60*8891	1	100											163	41	11
T60*B890	1-1/2	12											147	47	8
T60*B890	1-1/2	25												90	9
T60*B890	1-1/2	50												173	11
T60*B890	1-1/2	100													16
T60*B891	1-1/2	12												78	9
T60*B891	1-1/2	25												89	12
T60*B891	1-1/2	50												179	12
T60*B891	1-1/2	100													16
T60*B891	1-1/2	100												81	24
T60*B891	1-1/2	100												154	52

# Function Fittings and Flow Controls



## Pressure Reducing Fitting Inch and Metric



- **Compact size**
- **Easy tube insertion for rapid assembly of pneumatic circuits**
- **Push-in and threaded ports**
- **Optimum pressure utilization**
- **Safer pneumatic systems**
- **Hex key adjustment and locking ring**
- **Relieving**

### Technical Data

Fluid: Compressed air, nitrogen, inert and non-combustible gases compatible with materials of construction.

**Note:** For other types of fluids or compressed gases, please consult factory.

Operating Pressure:

Primary (inlet) pressure 0 to 150 psi (0 - 10 bar)

Maximum secondary (regulated) pressure 115 psi (8 bar)

Operating Temperature:

0° to 175°F (-20° to +80°C)

Outlet Port:

5/32", 1/4", 5/16", 3/8", 1/2" O.D. tube Push-in Fittings

1/8, 1/4, 3/8, 1/2 NPTF Threaded Ports

4, 6, 8, 10mm O.D. tube Push-in Fittings

Inlet Port:

1/8, 1/4, 3/8, 1/2 NPTF Thread

1/8, 1/4, 3/8, 1/2 ISO G Thread

Tubing Types:

Nylon 11 or 12, polyurethane (95 durometer or above)

LDPE (Low Density Polyethylene)

Materials

Nickel plated brass body

Nickel plated brass collet

Plastic sealing washer

Nitrile and polyurethane elastomeric parts

Zinc plated brass banjo bolt

### Ordering Information

To order, quote appropriate product number from the tables on the following pages.

Product numbering system is designed to make identification and selection simple:

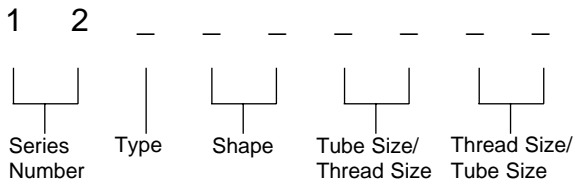

124GB

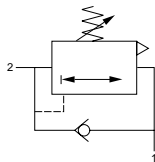

124GB

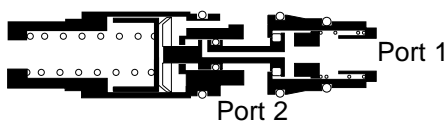



# Function Fittings and Flow Controls

Dimensions in Inches (mm)

## Pressure Reducing Fitting - 124GB

O.D. Tube

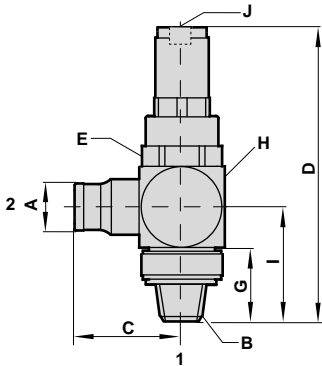

Part Number	A O/D Tube	B NPT Thread	C	D (max)	E A/F	G	H SQ A/F	I	J A/F
12 4GB 0218	5/32	1/8	0.89 (23)	2.87 (73)	0.67 (17)	—	0.63 (16)	0.78 (20)	0.20 (5)
12 4GB 0418	1/4	1/8	0.91 (23)	2.87 (73)	0.67 (17)	—	0.63 (16)	0.78 (20)	0.20 (5)
12 4GB 0428	1/4	1/4	1.0 (25)	3.10 (79)	0.67 (17)	0.64 (16)	0.79 (20)	1.02 (26)	0.20 (5)
12 4GB 0528	5/16	1/4	1.03 (26)	3.10 (79)	0.67 (17)	0.64 (16)	0.79 (20)	1.02 (26)	0.20 (5)
12 4GB 0538	5/16	3/8	1.11 (28)	3.35 (85)	0.87 (22)	0.69 (18)	0.94 (24)	1.14 (29)	0.34 (6)
12 4GB 0638	3/8	3/8	1.29 (33)	3.35 (85)	0.87 (22)	0.69 (18)	0.94 (24)	1.14 (29)	0.34 (6)
12 4GB 0748	1/2	1/2	1.56 (40)	3.54 (90)	1.06 (27)	—	1.18 (30)	1.38 (35)	0.24 (6)

- 1) Inlet Port
- 2) Outlet Port

Note: For mounting in ports 2 & 4 of a pneumatic directional control valve

## Pressure Reducing Fitting - 124GB

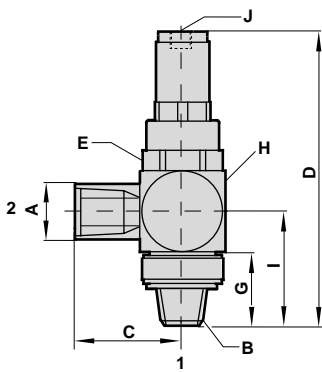

Part Number	A NPT Thread	B NPT Thread	C	D (max)	E A/F	G	H SQ A/F	I	J A/F
12 4GB 1818	1/8	1/8	0.83 (21)	2.87 (73)	0.67 (17)	—	0.64 (16)	0.78 (20)	0.20 (5)
12 4GB 2828	1/4	1/4	1.14 (29)	3.10 (79)	0.67 (17)	0.64 (16)	0.79 (20)	1.02 (26)	0.20 (5)
12 4GB 3838	3/8	3/8	1.20 (31)	3.35 (85)	0.87 (22)	0.69 (18)	0.94 (24)	1.14 (29)	0.24 (6)
12 4GB 4848	1/2	1/2	1.54 (39)	3.54 (90)	1.06 (27)	—	1.18 (30)	0.98 (35)	0.24 (6)

- 1) Inlet Port
- 2) Outlet Port

Note: For mounting in ports 2 & 4 of a pneumatic directional control valve

## Pressure Reducing Fitting - 102GB

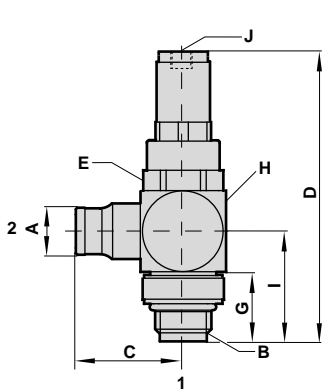

Part Number	A O/D tube	B ISO G Thread	C	D (max)	E A/F	G	H SQ A/F	I	J A/F
10 2GB 0418	4	1/8	0.89 (22)	2.87 (73)	0.67 (17)	0.25 (6)	0.64 (16)	0.78 (20)	0.20 (5)
10 2GB 0628	6	1/4	1.00 (25)	3.54 (90)	0.67 (17)	0.41 (11)	0.79 (20)	1.02 (26)	0.20 (5)
10 2GB 0828	8	1/4	1.03 (26)	3.54 (90)	0.67 (17)	0.41 (11)	0.79 (20)	1.02 (26)	0.20 (5)
10 2GB 0838	8	3/8	1.11 (28)	3.78 (96)	0.87 (22)	0.43 (11)	0.94 (24)	1.14 (29)	0.24 (6)
10 2GB 1038	10	3/8	1.29 (33)	3.78 (96)	0.87 (22)	0.43 (11)	0.94 (24)	1.14 (29)	0.24 (6)
Part Number	A ISO G Thread	B ISO G Thread	C	D (max)	E A/F	G	H SQ A/F	I	J A/F
10 2GB 1818	1/8	1/8	0.69 (18)	2.87 (73)	0.67 (17)	0.25 (6)	0.64 (16)	0.78 (20)	0.20 (5)
10 2GB 2828	1/4	1/4	0.96 (25)	3.19 (81)	0.37 (17)	0.41 (11)	0.79 (20)	1.02 (26)	0.20 (5)
10 2GB 3838	3/8	3/8	1.06 (27)	3.46 (88)	0.87 (22)	0.43 (11)	0.94 (24)	1.14 (29)	0.24 (6)
10 2GB 4848	1/2	1/2	1.34 (34)	3.50 (89)	1.06 (27)	0.37 (10)	1.18 (30)	1.42 (36)	0.24 (6)

- 1) Inlet Port
- 2) Outlet Port

Note: For mounting in ports 2 & 4 of a pneumatic directional control valve



**Flow characteristics at primary pressure of 100 psi (7 bar)**  
Inch and Metric Versions

**1/8 Pipe**

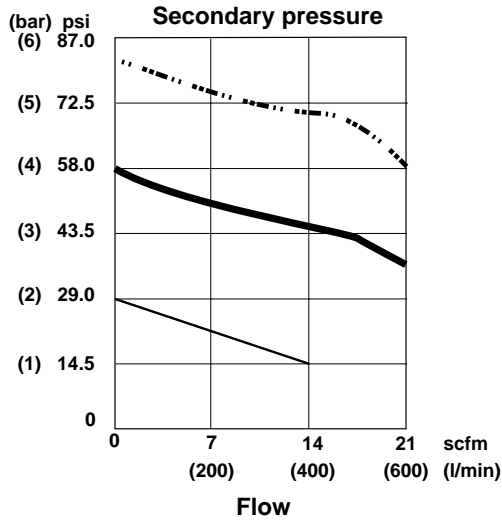

**1/4 Pipe**

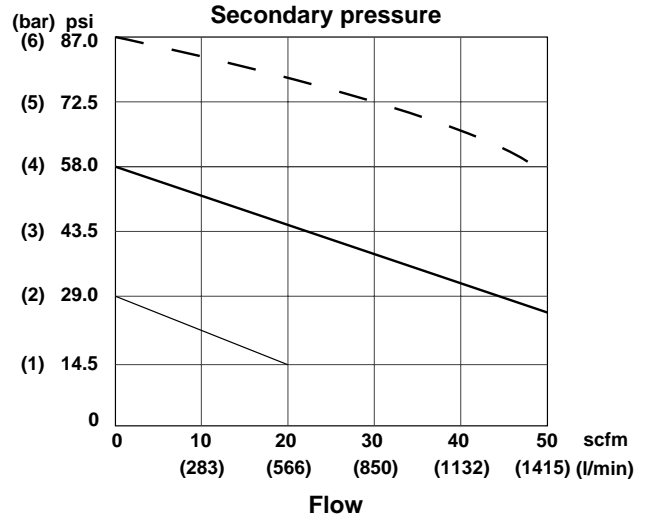

**3/8 and 1/2 Pipe**

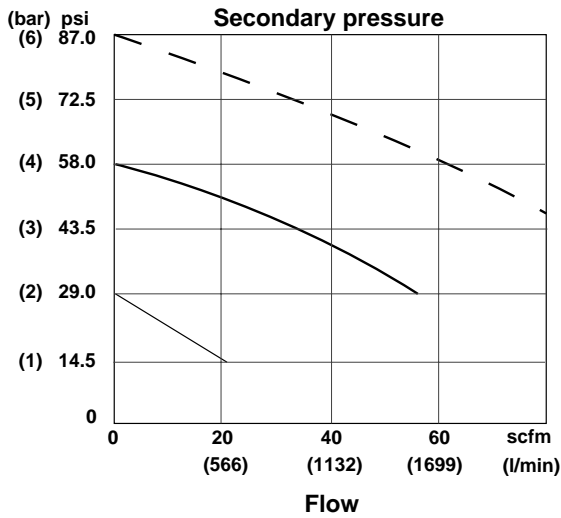

## Pilot Operated Check Valve Inch and Metric

- Compact size
- Easy tube insertion for rapid assembly of pneumatic circuits
- Positive tube retention
- Safer pneumatic systems
- Push-in and threaded ports

### Technical Data

Fluid: Compressed air, nitrogen, inert and non-combustible gases compatible with materials of construction.

**Note:** For other types of fluids or compressed gases, please consult factory.

Operating Pressure:  
15-150 psi (1 - 10 bar)

Operating Temperature:  
0° to 175°F (-20° to +80°C)

Inlet Port:  
1/4", 3/8", 1/2" O.D. tube Push-in Fittings  
1/8, 1/4, 3/8, 1/2 NPTF Threaded Ports  
6, 8, 10, 12mm O.D. tube Push-in Fittings

Outlet Port:  
1/8, 1/4, 3/8, 1/2 NPTF Thread\*  
1/4, 3/8, 1/2 ISO G Thread

\* Male NPTF threads (port 2) should be assembled hand tight and then wrenched no more than 1/2 to 3/4 turn.

NPTF Thread (male)	Maximum Tightening Torque ft lbs (Nm)
1/8	5 (7)
1/4	11 (15)
3/8	14 (20)
1/2	14 (20)

Signal Port:  
10-32 UNF on NPT ported models  
M5 on metric models

Tube Sizes  
1/4", 3/8", 1/2" O/D  
6, 8, 10, 12mm O/D

Tubing Types:  
Nylon 11 or 12, polyurethane (95 durometer or above), and LDPE (Low Density Polyethylene)

### Materials

Nickel plated brass body  
Nickel plated brass collet  
Plastic sealing washer (ISO G)  
Nitrile and polyurethane elastomeric parts  
Zinc plated brass banjo bolts



### Ordering Information

To order, quote appropriate product number from the tables on the following pages.

Product numbering system is designed to make identification and selection simple:

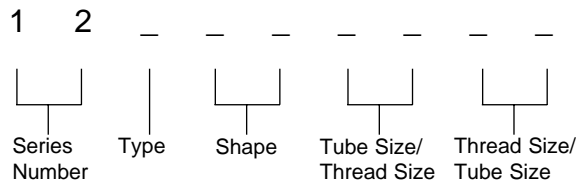

124GA

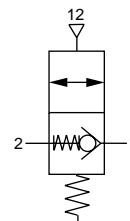

124GA

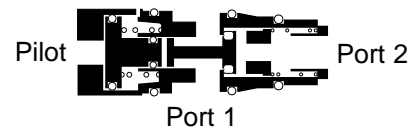

Flow Rates (scfm)				
Port Size	1/8	1/4	3/8	1/2
From 2 to 1 P12 = 88 psi	10.2	23.9	40.8	67.4
From 1 to 2 P12 = 0 psi	4.5	21.8	41.3	66.7



## Pilot Operated Check Valve - 124GA

Inch O.D. Tube x NPTF thread

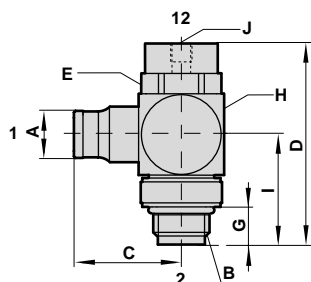

Product Number	A O.D. Tube	B NPT Thread	C	D	E A/F	G	H SQ A/F	I	J
12 4GA 0418	1/4"	1/8	0.91 (23)	1.61 (41)	0.51 (13)	0.48 (12)	0.63 (16)	0.78 (20)	10-32 UNF
12 4GA 0428	1/4"	1/4	0.99 (25)	1.89 (48)	0.67 (17)	0.64 (16)	0.79 (20)	1.02 (26)	10-32 UNF
12 4GA 0638	3/8"	3/8	1.29 (33)	2.16 (55)	0.87 (22)	0.69 (18)	0.94 (24)	1.14 (29)	10-32 UNF
12 4GA 0748	1/2"	1/2	1.56 (40)	2.58 (66)	1.06 (27)	0.87 (22)	1.18 (30)	1.42 (36)	10-32 UNF

- 1) Inlet Port
- 2) Outlet Port
- 12) Signal Port

Note: For mounting in pairs on a cylinder

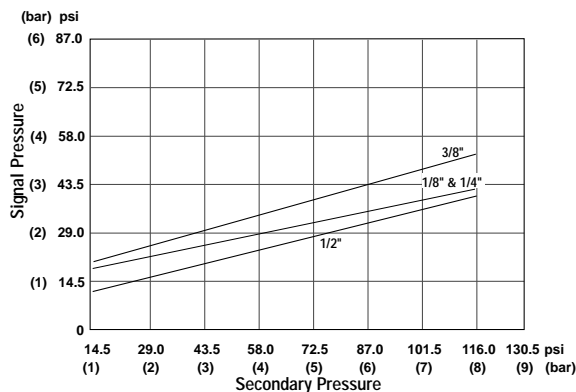

## Pilot Operated Check Valve - 124GA

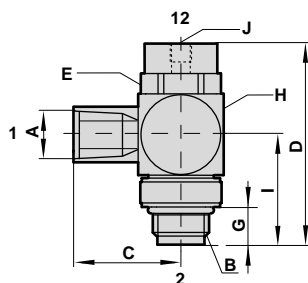

Product Number	A NPT Thread	B NPT Thread	C	D	E	G A/F	HSQ A/F	I	J
12 4GA 1818	1/8	1/8	0.87 (22)	1.61 (41)	0.51 (13)	0.48 (12)	0.63 (16)	0.78 (20)	10-32 UNF
12 4GA 2828	1/4	1/4	1.14 (29)	1.89 (48)	0.67 (17)	0.64 (16)	0.79 (20)	1.02 (26)	10-32 UNF
12 4GA 3838	3/8	3/8	1.20 (31)	2.17 (55)	0.87 (22)	0.69 (18)	0.94 (24)	1.14 (29)	10-32 UNF
12 4GA 4848	1/2	1/2	1.54 (39)	2.58 (66)	1.06 (27)	0.87 (22)	1.18 (30)	1.42 (36)	10-32 UNF

- 1) Inlet Port
- 2) Outlet Port
- 12) Signal Port

Note: For mounting in pairs on a cylinder

## Pilot Operated Check Valve - 102GA

mm O.D. tube x ISO G thread

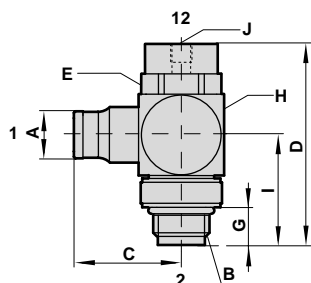

Product Number	A O/D tube	B ISO G Thread	C	D	E A/F	G	HSQ A/F	I	J
10 2GA 0628	6	1/4	0.99 (25)	1.87 (48)	0.67 (170)	0.41 (11)	0.79 (20)	1.02 (26)	M5
10 2GA 0828	8	1/4	1.03 (26)	1.87 (48)	0.67 (17)	0.41 (11)	0.79 (20)	1.02 (26)	M5
10 2GA 0838	8	3/8	1.11 (28)	2.15 (55)	0.87 (22)	0.43 (11)	0.94 (24)	1.14 (29)	M5
10 2GA 1038	10	3/8	1.29 (33)	2.15 (55)	0.87 (22)	0.43 (11)	0.94 (24)	1.14 (29)	M5
10 2GA 1248	12	1/2	1.56 (40)	2.56 (65)	1.06 (27)	0.50 (13)	1.18 (30)	1.42 (36)	M5

- 1) Inlet Port
- 2) Outlet Port
- 12) Signal Port

Note: For mounting in pairs on a cylinder

- Compact units
- Easy tube insertion for rapid assembly of pneumatic circuits
- Positive tube retention
- Simplifies pneumatic systems
- Eliminates need for electrical reed switches
- Exhausts on signal side (port 2)



### Technical Data

Fluid: Compressed air, nitrogen, inert and non-combustible gases compatible with materials of construction.

**Note:** For other types of fluids or compressed gases, please consult factory.

#### Operating Pressure:

Cylinder pressure (Pc)	145 psi (10 bar) max
Sensor supply pressure	43 to 145 psi (3 - 10 bar)
Sensor switch pressure	14.5 psi (1.0 bar) typical

#### Operating Temperature:

0° to 175°F (-20° to +80°C)

#### Body Ports

- 5/32" O.D. tube Push-in
- 4mm O.D. tube Push-in
- 1/8, 1/4 NPTF Banjo Bolt
- 1/8, 1/4 ISO G Banjo Bolt

#### Tube Sizes

- 5/32" O/D
- 4mm O/D

#### Tubing Types:

- Nylon 11 or 12, polyurethane (95 durometer or above) and LPDE (Low Density Polyethylene)

### Materials

Body, swivel fitting and collet: Nickel plated brass

O-ring: Silicone free Nitrile

Sealing washer (parallel male threads): Thermoplastic

Tubing: Nylon 11 or 12, Polyurethane (95 durometer or above) and LDPE (Low Density Polyethylene).

**Note:** Lower durometer polyurethane may be used, however, an internal tube support is required to prevent internal collapse of the tube wall.

### Ordering Information

To order, quote appropriate product number from the tables on the following pages.

Product numbering system is designed to make identification and selection simple:

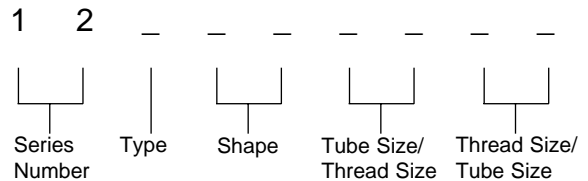

124GD

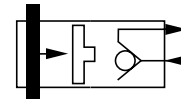

124GD

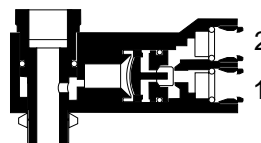



**Pressure Sensor Fitting- 124GD**

Inch O.D. tube x NPTF Banjo Bolt

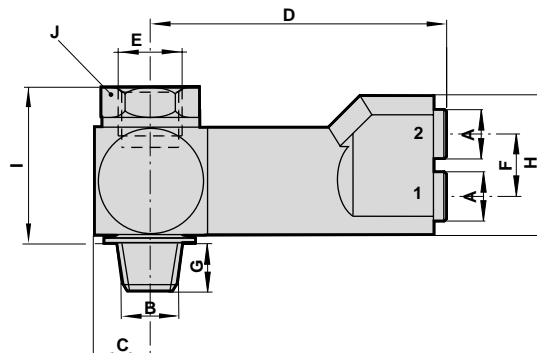

Product Number	A Tube O/D	B NPT Thread	C	D	E NPT Thread	F	G	H	I	J A/F
12 4GD 0218	5/32"	1/8	0.35 (9)	1.77 (45)	1/8	0.39 (10)	0.39 (10)	0.83 (21)	1.12 (29)	9/16"
12 4GD 0228	5/32"	1/4	0.43 (11)	1.85 (47)	1/4	0.39 (10)	0.56 (14)	0.83 (21)	1.33 (34)	3/4"

This sensor fitting produces an end of stroke signal when exhaust back pressure in a cylinder decays below a set value. It should be mounted directly on the cylinder and can be used with a flow control device mounted into the top port.

It is recommended that the sensor supply pressure to port 1 be the same as the nominal working pressure of the cylinder.

**Pressure Sensor Fitting- 102GD**

mm O.D. tube x ISO G Banjo Bolt

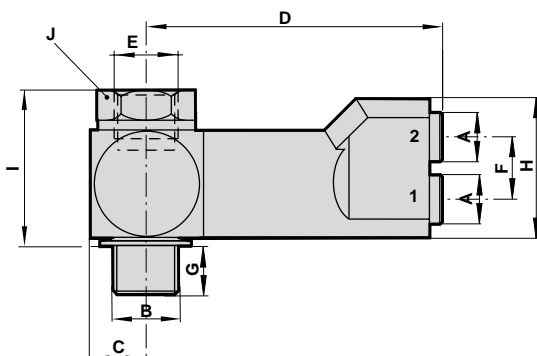

Product Number	A Tube O/D	B ISO G Thrd	C	D	E ISO G thread	F	G	H	I	J A/F
10 2GD 0418	4	1/8	0.35 (9)	1.77 (45)	1/8	0.39 (10)	0.24 (6)	0.83 (21)	0.98 (25)	0.59 (15)
10 2GD 0428	4	1/4	0.43 (11)	1.85 (47)	1/4	0.39 (10)	0.28 (7)	0.83 (21)	1.14 (29)	0.75 (19)

This sensor fitting produces an end of stroke signal when exhaust back pressure in a cylinder decays below a set value. It should be mounted directly on the cylinder and can be used with a flow control device mounted into the top port.

It is recommended that the sensor supply pressure to port 1 be the same as the nominal working pressure of the cylinder.

- Enables air to be exhausted quickly from air reservoirs and cylinders
- Allows higher cylinder speeds to be achieved
- Simple, compact design and construction
- Reliable operation



### Technical Data

#### Fluid:

Compressed air, filtered, lubricated and non-lubricated

#### Operation:

Diaphragm

#### Mounting:

Line mounted

#### Port Size:

#### Female Thread

(Inlet, outlet and exhaust ports)

NPT		ISO G	
1/8 NPT	<b>T70A1800</b>	G1/8	<b>T70C1800</b>
1/4 NPT	<b>T70A2800</b>	G1/4	<b>T70C2800</b>
3/8 NPT	<b>T70A3800</b>	G3/8	<b>T70C3800</b>
1/2 NPT	<b>T70A4800</b>	G1/2	<b>T70C4800</b>
3/4 NPT	<b>C/511*</b>		

\* Note: C/511 has 1/2" NPT inlet port and 3/4" NPT outlet ports.

#### Operating Pressure:

7 - 145 psi (0.5 - 10 bar)

#### Operating Temperature:

0° to 175°F (-20°\*\* to +80°C)

\*\*Consult our Technical Service for use below 35°F (2°C)

### Materials

Zinc or aluminum alloy body and cover, nitrile seals (PU seal on C/511).

### Ordering Information

To order, quote model number from page FIT-3-21, e.g. T70A2800 for the NPT ported version. This range replaces the C/510 and S/510 models.

### Quick Exhaust Valve

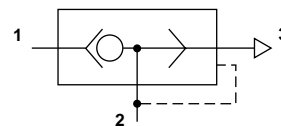

### Typical Fill and Exhaust Times (seconds)

Model	Port size	Volume	Fill time	Exhaust time
T70A1800	1/8" NPT	150 cc	0.036	0.021
T70A2800	1/4" NPT	150 cc	0.023	0.017
T70A3800	3/8" NPT	1500 cc	0.110	0.080
T70A4800	1/2" NPT	15,000 cc	0.460	0.480
C/511	3/4" NPT	15,000 cc	0.480	0.250

Note: Fill time is 0 to 80 psig (0 to 5.5 bar), and exhaust time is 101 to 20 psig (7.0 to 1.4 bar)



## General Information

Model NPT	Model ISO G	Inlet port	Outlet port	Exhaust port	Cv Flow Factor Direction 1 - 2*	Cv Flow Factor Direction 2 - 3	Weight oz (kg)	Repair kit (seals only)
T70A 1800	T70C 1800	1/8	1/8	1/8	0.9	1.8	5.3 (0.15)	T70C1800K0
T70A 2800	T70C 2800	1/4	1/4	1/4	1.9	2.5	4.6 (0.13)	T70C2800K0
T70A 3800	T70C 3800	3/8	3/8	3/8	3.8	5.5	7.4 (0.21)	T70C3800K0
T70A 4800	T70C 4800	1/2	1/2	1/2	5.3	5.9	6.7 (0.19)	T70C4800K0
C/511	S/511	1/2	3/4	3/4	**1.9/5.1	10.8	11.0 (0.31)	QS/511/00

\* Flow factor measured at 87 psi (6 bar) (inlet) guideline direction

\*\* Alternative Cv shown for 14.5 psi (1 bar). For T70 Series, Cv approximately the same as at 6 bar.

NPT threads per ANSI B1.20.1

## Quick Exhaust Valve

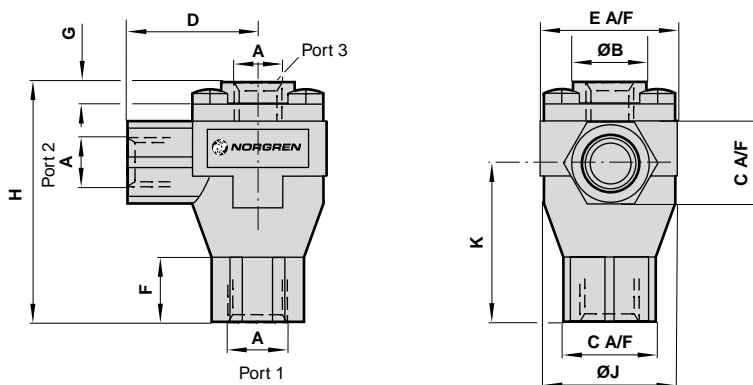

Model	T70A1800	T70C1800	T70A2800	T70C2800	T70A3800	T70C3800	T70A4800	T70C4800	C/511*
A	1/8 NPT	G1/8	1/4 NPT	G1/4	3/8 NPT	G3/8	1/2 NPT	G1/2	1/20 - 3/4
ØB	0.75 (19)	0.75 (19)	0.75 (19)	0.75 (19)	1.18 (30)	1.18 (30)	1.18 (30)	1.18 (30)	—
C A/F	0.75 (19)	0.75 (19)	0.75 (19)	0.75 (19)	1.18 (30)	1.18 (30)	1.18 (30)	1.18 (30)	—
D	1.10 (28)	1.10 (28)	1.10 (28)	1.10 (28)	1.57 (40)	1.57 (40)	1.57 (40)	1.57 (40)	2.0 (50)
E A/F	1.18 (30)	1.18 (30)	1.18 (30)	1.18 (30)	1.81 (46)	1.81 (46)	1.81 (46)	1.81 (46)	1.87 (47.5)
F	0.60 (15.3)	0.60 (15.3)	0.60 (15.3)	0.60 (15.3)	0.61 (15.5)	0.61 (15.5)	0.61 (15.5)	0.61 (15.5)	—
G	0.14 (3.5)	0.14 (3.5)	0.14 (3.5)	0.14 (3.5)	0.16 (4)	0.16 (4)	0.16 (4)	0.16 (4)	—
H	2.09 (53)	2.09 (53)	2.09 (53)	2.09 (53)	2.89 (73.5)	2.89 (73.5)	2.89 (73.5)	2.89 (73.5)	3.38 (86)
ØJ	1.14 (29)	1.14 (29)	1.14 (29)	1.14 (29)	1.81 (46)	1.81 (46)	1.81 (46)	1.81 (46)	—
K	1.40 (35.5)	1.40 (35.5)	1.40 (35.5)	1.40 (35.5)	1.89 (48)	1.89 (48)	1.89 (48)	1.89 (48)	2.72 (69)

\* Note the shape of the C/511 is different. Consult our technical department for the exact specifications.

## T70 Series Flowrate

Choked flow versus inlet pressure  
(1 - 2) + (2 - 3)

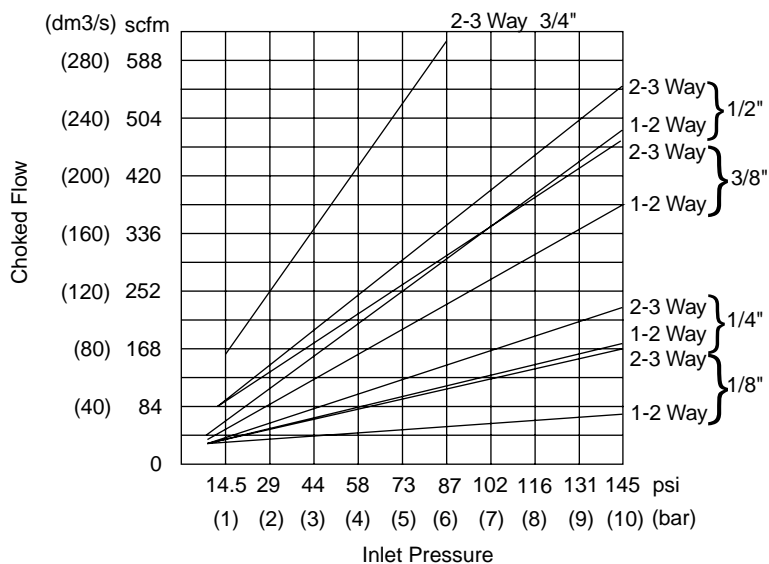

- Allow two independent signal sources to be connected to a common pilot line
- Can be used to perform an 'OR' logic function
- Selects the highest of two applied pressures
- Can be combined to operate from three or more sources
- Valves can be ganged together



### Technical Data

#### Fluid:

Compressed air, filtered, lubricated and non-lubricated, inert gases

#### Operation:

Shuttle valve

#### Mounting:

Through holes in valve body

#### Port Size:

Female Thread

NPT	ISO G
1/8 NPT <b>T65A1800</b>	G1/8 <b>T65C1800</b>
1/4 NPT <b>T65A2800</b>	G1/4 <b>T65C2800</b>

#### Operating Pressure:

10 to 145 psi (0.7 - 10 bar)

#### Operating Temperature:

0° to 175°F (-20°\* to +80°C)

\*Consult our Technical Service for use below 35°F (2°C)

### Materials

Body: Zinc

Ball: Nitrile

Seat: Brass

### Ordering Information

To order, quote model number from table on page. FIT-3-19, e.g. T65A1800 for the 1/8" NPT.

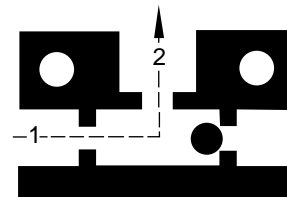
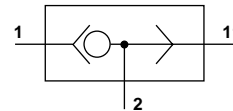



Product Number		Port Size	Flow Factor Cv	Weight oz. (kg)
NPT	ISO G			
T65A1800	T65C1800	1/8	0.42	1.9 (.055)
T65A2800	T65C2800	1/4	0.64	4.6 (.130)

NPT according to ANSI B1.20.1

Shuttle Valve

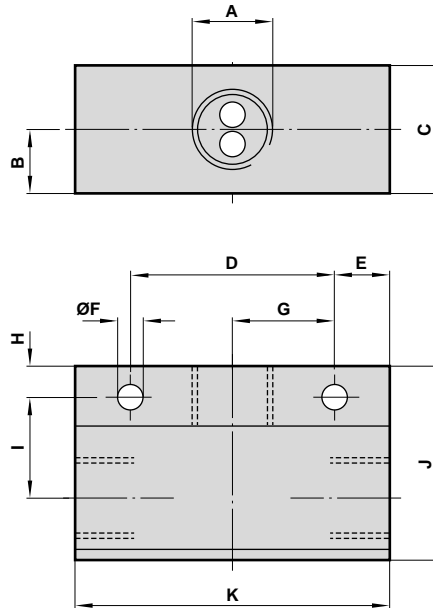

Model	A	B	C	D	E	F	G	H	I	J	K
T65A 1800	1/8 NPT	0.30 (8)	0.59 (15)	0.79 (20)	0.3 (8)	0.21 (5)	0.39 (10)	0.24 (6)	0.39 (10)	1.00 (25)	1.42 (36)
T65C 1800	G1/8	0.30 (8)	0.59 (15)	0.79 (20)	0.3 (8)	0.21 (5)	0.39 (10)	0.24 (6)	0.39 (10)	1.00 (25)	1.42 (36)
T65A 2800	NPT1/4	0.39 (10)	0.79 (20)	0.98 (25)	0.49 (13)	0.21 (5)	0.49 (13)	0.31 (8)	0.47 (12)	1.18 (30)	2.00 (50)
T65C 2800	G1/4	0.39 (10)	0.79 (20)	0.98 (25)	0.49 (13)	0.21 (5)	0.49 (13)	0.31 (8)	0.47 (12)	1.18 (30)	2.00 (50)

NPT according to ANSI B1.20.1

G according to BS 2779/ISO 228/1