

Precision and Instrument Regulators

1/4" port size

Contents

11-018 Precision Air Pressure Regulator 1/4" portsALE-8-2
R38 Instrument Regulator Aluminum Model 1/4" portsALE-8-4



11-018



R38

**Precision Air Pressure Regulator
1/4" Port Size**

- **Fast response**
- **Minimum overshoot during flow changes**
- **Precision regulation obtained by pilot valve design - small change in the pilot valve position results in a large change in the main valve position**
- **Constant bleed feature provides maximum sensitivity to system changes**
- **Relieving feature allows reduction of downstream pressure when the system is dead-ended**



Ordering Information. Models listed have PTF threads, hand wheel adjustment, and relieving diaphragm. A gauge is not included.

Port Size	Outlet Pressure Adjustment Range*	Model Number	Flow scfm (dm ³ /s)	Weight lbs (kg)
1/4"	0.4 to 10 psig (0.03 to 0.69 bar)	11-018-146	12 (5.66)†	1.4 (0.64)
1/4"	1.0 to 60 psig (0.1 to 4.1 bar)	11-018-100	12 (5.66)†	1.4 (0.64)
1/4"	3 to 150 psig (0.2 to 10.3 bar)	11-018-110	12 (5.66)††	1.4 (0.64)

* Outlet pressure can be adjusted to pressures in excess of, and less than, those specified. Do not use these units to control pressures outside of the specified ranges.

† Typical flow with 100 psig (7 bar) inlet pressure, 60 psig (4.1 bar) set pressure and 0.125 psig (0.009 bar) droop from set.

†† Typical flow with 200 psig (14 bar) inlet pressure, 60 psig (4.1 bar) set pressure and 0.250 psig (0.017 bar) droop from set.

Alternative Models

Threads	Substitute
PTF	0
ISO G parallel	8
ISO G Rc	9

1 1 - ★ 1 8 - ★ ★ ★

Screw Adjustment	Substitute
-100 with slotted screw adjustment	101
-110 with slotted screw adjustment	112

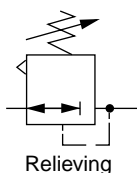
ISO Symbols

Service Kits

Type	Part number
Low Pressure Models	2787-01
High Pressure Models	2787-02
Special tool to install main valve seat	681-01

Service kit includes o-rings, seals, pilot diaphragm, pilot spring, main diaphragm, main valve, main valve seat, diffuser screen, constant bleed orifice and orifice filter

See Section ALE-25 for Accessories



Typical Performance Characteristics

Technical Data

Fluid: Compressed air

Low Pressure Models:

11-018-100 and 11-018-146

High Pressure Models:

11-018-110

Inlet pressure range*

Low Pressure Models: 8 to 150 psig (0.55 to 10.3 bar)

High Pressure Models: 10 to 200 psig (0.7 to 13.8 bar)

* Inlet pressure must be at least 7 psig (0.5 bar) greater than the adjusted outlet pressure for proper operation.

Operating temperature*: 32° to 160°F (0° to 70°C)

** Air supply must be dry enough to avoid ice formation at temperatures below 35°F (2°C).

Flow capacity with 100 psig (6.9 bar) inlet pressure

11-018-146: 12 scfm (5.7 dm³/s) with set pressure of 10 psig (0.7 bar)

11-018-100 and 11-018-110: 20 scfm (9.4 dm³/s) with set pressure of 20 psig (1.4 bar). A small pressure droop occurs at flows above 12 scfm (5.7 dm³/s).

Repeatability

Low Pressure Models: 0.02 psig (0.001 bar) for flow change; 0.05 psig (0.004 bar) when turning supply off and on

High Pressure Models: 0.08 psig (0.006 bar) for flow change; 0.16 psig (0.011 bar) when turning supply off and on

Constant bleed feature: Under dead-end conditions, a small, constant bleed of pilot air will escape thru the relief passage in the bottom plug. This will be accompanied by a slight residual outlet pressure of 1 to 4 inches H₂O (2.5 to 10 millibar).

Gauge ports:

1/4" PTF with PTF main ports

Rc1/4 with ISO G and ISO Rc main ports

Materials

Body: Zinc

Bonnet: Zinc

Main valve: Polycarbonate

Main valve seat: Teflon

Pilot valve: Stainless steel

Pilot valve seat: Aluminum

Main diaphragm: Nitrile

Pilot diaphragm

Low Pressure Models: Beryllium copper

High Pressure Models: Nitrile

Bottom plug: Brass

Elastomers: Nitrile, neoprene, polyurethane

All Dimensions in Inches (mm)

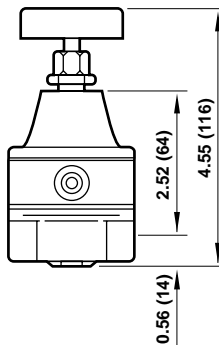
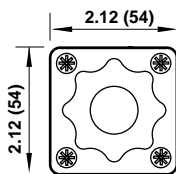

Panel mounting hole diameter: 0.47" (12 mm)

Maximum panel thickness: 0.094" (2.4 mm)

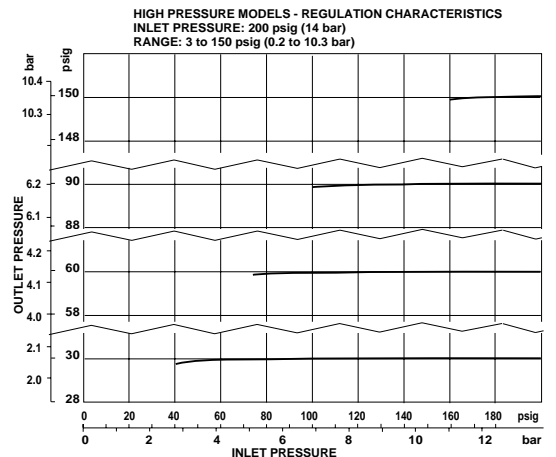
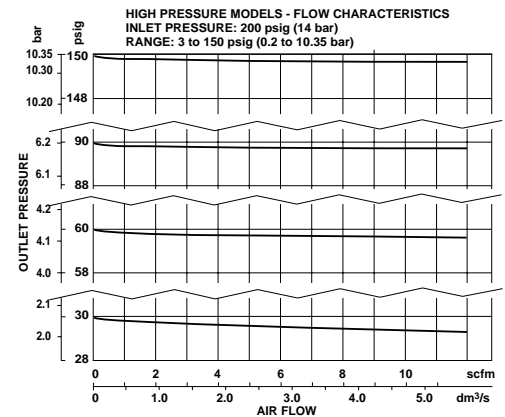
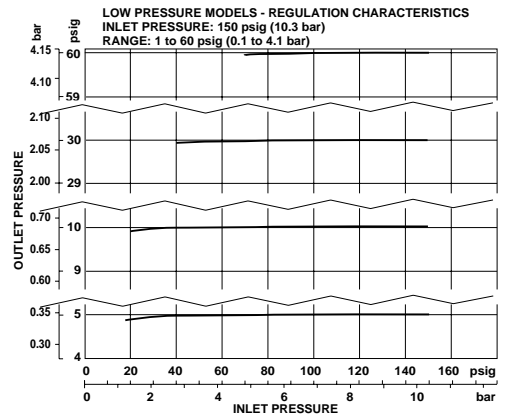
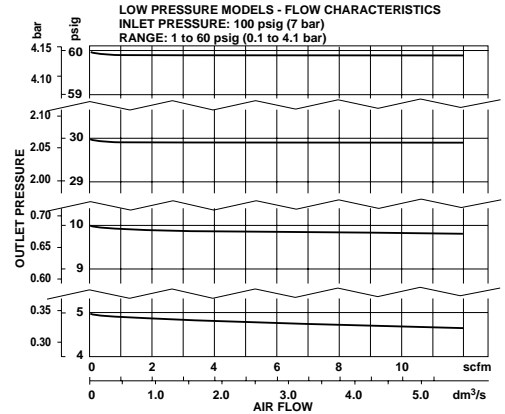

**Instrument Regulator
Aluminum Model 1/4" Port Size**

- Compact instrument units with high performance
- Stable regulation with temperature compensation
- Excellent flow and regulation characteristics
- Panel Mounting facility



Ordering Information. Models listed are relieving type with 0.6 to 30 psig (0.04 to 2 bar) outlet pressure adjustment range *, and PTF threads. A gauge is not included.

Port Size	Model Number	Flow [†] scfm (dm ³ /s)	Weight lbs (kg)
1/4" PTF	R38-200-RNCA	17 (8)	1.06 (0.48)

† Typical flow with 100 psig (7 bar) inlet pressure, 15 psig (1 bar) set pressure and 1 psig (0.05 bar) droop from set.

R 3 8 - ★ ★ ★ - ★ ★ ★ ★			
Port Size	Substitute	Threads	Substitute
1/4" PTF	2	PTF	A
Material	Substitute	ISO Rc taper	B
Aluminum, nitrile elastomers	0	ISO G parallel	D
Aluminum, Viton elastomers	1	API.LP.INT	K
Mounting Option	Substitute	Outlet Pressure Adjustment Ranges*	Substitute
Without	0	0.6 to 30 psig (0.04 to 2 bar)	C
With bracket and nut	1	1 to 60 psig (0.07 to 4 bar)	F
With panel nut only	2	3.6 to 100 psig (0.25 to 7 bar)	K
With handwheel and nut	3	Gauges	Substitute
With handwheel, bracket and nut	4	Without	N
With handwheel only	5	Diaphragm	Substitute
		Relieving	R
		Non relieving	N

* Outlet pressure can be adjusted to pressures in excess of, and less than, those specified. Do not use these units to control pressures outside of the specified ranges.

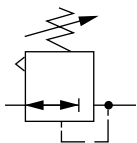
ISO Symbol

See Section ALE-25 for Accessories



Technical Data

Fluid: Compressed air

Maximum pressure: 290 psig (20 bar)

Operating temperature: -40° to 175°F (-40° to 80°C) *

* Air supply must be dry enough to avoid ice formation at temperatures below 35°F (2°C).

Typical flow at 100 psig (7 bar) inlet pressure, 15 psig (1 bar) set pressure and a droop of 1 psig (0.07 bar) from set: 17 scfm (8 dm³/s)

Typical relief differential at 30 psig (2 bar) outlet pressure:

2.3 psig (0.16 bar)

Maximum bleed flow at 30 psig (2 bar) outlet pressure (relieving types only):

0.003 scfm (1.5 cm³/s)†

† Maximum bleed rate occurs under dead-end (noflow) conditions.

Gauge ports:

1/4 NPT

Materials

Body: Aluminum

Bonnet: Aluminum

Adjusting screw: Steel

Elastomeric materials: Nitrile

All Dimensions in Inches (mm)

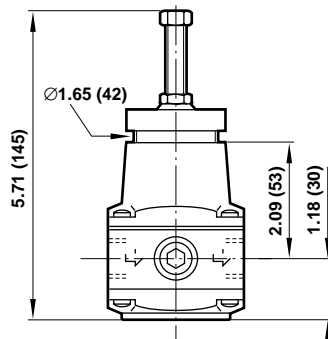
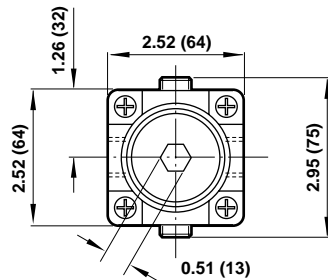

Panel mounting hole diameter: 1.65" (42 mm)
Panel thickness: 0" to 0.24" (0 to 6 mm)

Typical Performance Characteristics

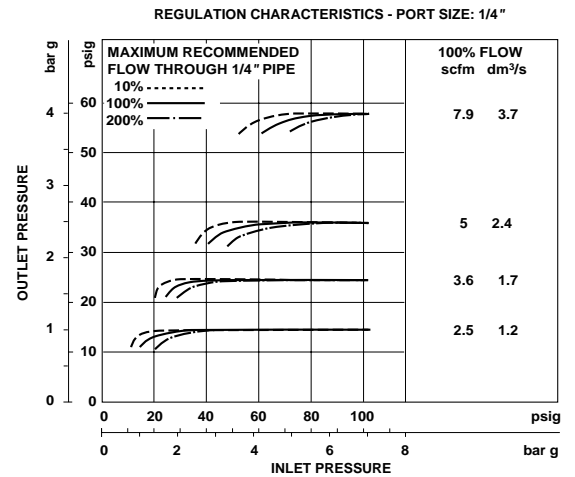
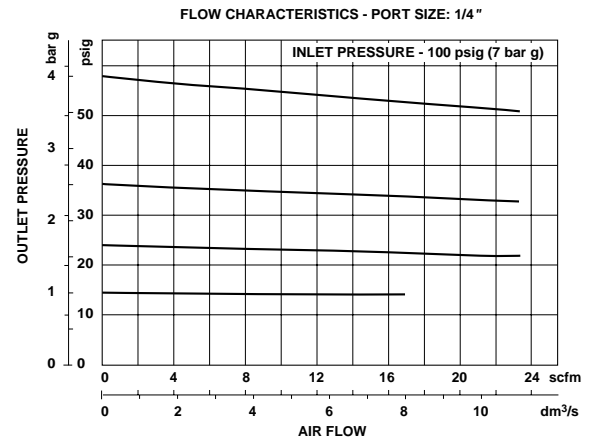

Service Kits

Item	Type	Part number
30 psig (2 bar) Range	Relieving	R38-100-R
	Non relieving	R38-100-NR
60, 105 psig (4 bar, 7 bar) Range	Relieving	R38-101-R
	Non relieving	R38-101-NR

Service kit includes diaphragm assembly, o-ring, valve, valve spring and 8 pan head screws.