

Oil Removal (Coalescing) Filters

Port sizes from 1/8" to 2"

F39 Miniature Oil Removal Filter 1/8" and 1/4" Ports	ALE-2-2
F72C Excelon Oil Removal Filter 1/4" and 3/8" Ports	ALE-2-4
F73C Excelon Oil Removal Filter 1/4", 3/8", and 1/2" Ports	..	ALE-2-6
F74C/H Excelon Oil Removal Filter 3/8", 1/2", and 3/4" Ports	ALE-2-8
F64C/H Olympian Plus Oil Removal Filter 1/4", 3/8", 1/2", and 3/4" Ports	ALE-2-10
F68C/H Olympian Plus Oil Removal Filter 1/2", 3/4", and 1" Ports	ALE-2-12
F46 Oil Removal Filter 3/4", 1", and 1-1/4" Ports	ALE-2-14
F47 Oil Removal Filter 1-1/2" and 2" Ports	ALE-2-16



F39



F72C



F73C



F74C/H



F64C/H



F68



F46



F47

**Miniature Series 07 Oil Removal
(Coalescing) Filter 1/8" and 1/4" Port Sizes**

- Compact design
- High efficiency oil and particle removal
- Screw-on bowl reduces maintenance time
- Can be disassembled without the use of tools or removal from the air line



Ordering Information. Models listed include PTF threads, automatic drain and transparent bowl.

Port Size	Model Numbers	Saturated Flow* Flow scfm (dm ³ /s)	Dry Flow Flow scfm (dm ³ /s)	Weight lbs (kg)
1/8"	F39-100-A0TA	6.0 (2.8)	11.2 (5.3)	0.28 (0.13)
1/4"	F39-200-A0TA	6.4 (3.0)	12.2 (5.8)	0.28 (0.13)

* Maximum flow at 90 psig (6.3 bar) inlet pressure to maintain stated oil removal performance.

Alternative Models

F 3 9 - ★ ★ ★ - ★ ★ ★ ★

Port Size	Substitute
1/8"	1
1/4"	2

Option	Substitute
Not applicable	0

Option	Substitute
Not applicable	0

Threads	Substitute
PTF	A
ISO Rc taper	B
ISO G parallel	G

Bowl	Substitute
Transparent	T
Metal	M

Element	Substitute
Coalescing	0

Drain	Substitute
Automatic	A
Manual	M

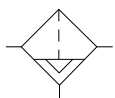
ISO Symbols

Automatic and
Semi Automatic Drain

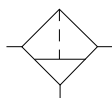

Manual Drain

See Section ALE-25 for Accessories



Technical Data

Fluid: Compressed air

Maximum pressure:

Transparent bowl: 150 psig (10 bar)

Metal bowl: 250 psig (17 bar)

Operating temperature:*

Transparent bowl: -30° to 125°F (-34° to 50°C)

Metal bowl: -30° to 150°F (-34° to 65°C)

* Air supply must be dry enough to avoid ice formation at temperatures below 2°C (35°F)

Particle removal: Down to 0.01 µm

Air quality: Within ISO 8573-1, Class 1 (particulates) and Class 2 (oil content)

Maximum remaining oil content of air leaving the filter: 0.01ppm at 70°F (21°C) with an inlet oil concentration of 17 ppm.

Maximum flow with 90 psig (6.3 bar) inlet pressure†:

1/8 ports, 6.0 scfm (2.8 dm³/s)

1/4 ports, 6.4 scfm (3 dm³/s)

† Maximum flow to maintain stated oil removal performance.

Nominal bowl size: 1 fluid ounce (31 ml)

Drain connection: 1/8" pipe thread

Automatic drain operation: Spitter type drain operates momentarily when a rapid change in air flow occurs or when the supply pressure is reduced.

Materials:

Body: Zinc

Bowl:

Transparent: Polycarbonate

Metal: Zinc

Element: Synthetic fiber and polyurethane foam

Elastomers: Neoprene & nitrile

Typical Performance Characteristics

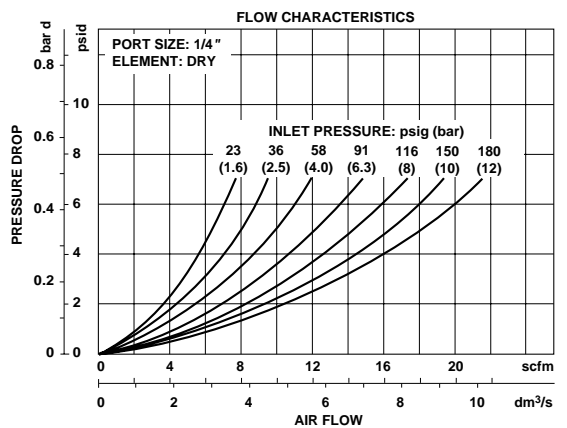
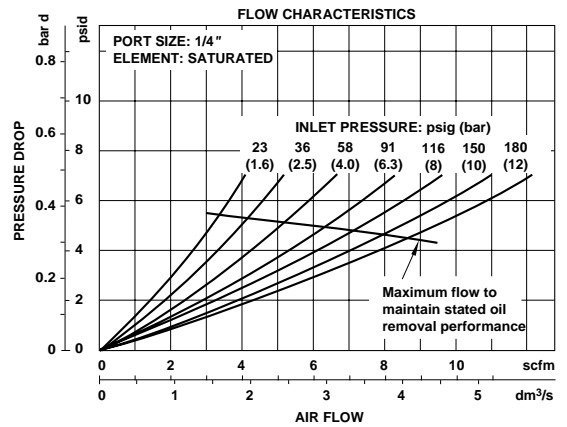

Service Kits

Item	Type	Part number
Service kit	All models	4141-10
Replacement drains	Manual	773-03
	Automatic	3654-02

Service kit includes element, element o-ring, and bowl o-ring.

All Dimensions in Inches (mm)

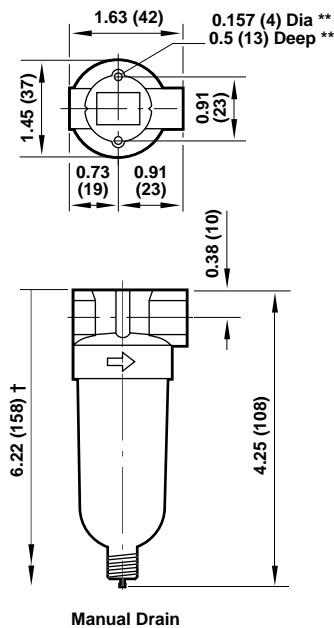

** Mounting holes

† Minimum clearance to remove bowl

**Excelon F72C Oil Removal Filter
(Coalescing) 1/4" and 3/8" Port Sizes**

- Excelon design allows in-line or modular installation
- High efficiency oil and particle removal
- Quick release bayonet bowl
- Highly visible, prismatic liquid level indicator lens on metal bowls
- Standard visual service life indicator turns from green to red when the filter element needs to be replaced
- Optional electrical service indicator also available
- Modular installations with Excelon 72, 73, and 74 series can be made to suit particular applications

Install an F72G filter with a 5 µm filter element upstream of the F72C filter for optimum coalescing element life.



Ordering Information. Models listed include PTF threads, service life indicator, automatic drain, long transparent bowl without guard.

Port Size	Model	Flow [†] scfm (dm ³ /s)	Weight lb (kg)
1/4"	F72C-2AD-ALO	9.5 (4.5)	1.2 (0.54)
3/8"	F72C-3AD-ALO	9.5 (4.5)	1.2 (0.54)

† Maximum flow with 90 psig (6.3 bar) inlet pressure, to maintain stated oil removal performance.

Alternative Models

F 7 2 C - ★ ★ ★ - ★ ★ ★

Port Size	Substitute
1/4"	2
3/8"	3

Threads	Substitute
PTF	A
ISO Rc taper	B
ISO G parallel	G

Service Life Indicator	Substitute
With (visual)	D
With (electrical)	E
Without	N

Element	Substitute
Coalescing	0

Bowl	Substitute
Short metal with liquid level indicator	D
Long metal with liquid level indicator	E
Short transparent without guard	T
Long transparent without guard	L
Long transparent with guard	W

Drain	Substitute
1/4 turn manual	Q
Semi automatic	S
Auto drain*	A

* Supplied in long bowl options only

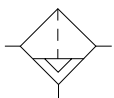
ISO Symbols

Automatic and
Semi Automatic Drain

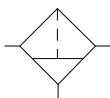

Manual Drain

See Section ALE-25 for Accessories



Technical Data

Fluid: Compressed air

Maximum pressure:

Transparent bowl: Manual or semi automatic drain: 150 psig (10 bar)
Automatic drain: 116 psig (8 bar)

Metal bowl: Manual or semi automatic drain: 250 psig (17 bar)
Automatic drain: 116 psig (8 bar)

Operating temperature*: Transparent bowl: -30° to 125°F (-34° to 50°C)
Metal bowl: -30° to 150°F (-34° to 65°C)

* Air supply must be dry enough to avoid ice formation at temperatures below 35°F (2°C).

Particle removal: 0.01 µm

Air quality: Within ISO 8573-1, Class 1 (particulates) and Class 2 (oil content)

Maximum remaining oil content in outlet air:

0.01 ppm at 70°F (21°C) with an inlet concentration of 17 ppm.

Maximum flow with 90 psig (6.3 bar) inlet pressure**: 9.5 scfm (4.5 dm³/s)

** Maximum flow to maintain stated oil removal performance.

Manual drain connection: Will fit 1/8-27 and 1/8-28 pipe thread.

Semi automatic drain connection: Push on 5/16" (8 mm) ID tube

Semi automatic drain operating conditions (pressure operated):

Bowl pressure required to close drain: Greater than 1.5 psig (0.1 bar)

Bowl pressure required to open drain: Less than 1.5 psig (0.1 bar)

Minimum air flow required to close drain: 1 scfm (0.5 dm³/s)

Manual operation: Lift stem to drain bowl

Automatic drain connection: Will fit 1/8-27 and 1/8-28 pipe thread. - Flexible tube with 3/16" (5mm) minimum I.D. can be connected to the automatic drain. Drain may fail to operate if the tube I.D. is less than 3/16" (5mm). Avoid restrictions in the tube.

Automatic drain operating conditions (float operated):

Bowl pressure required to close drain: Greater than 5 psig (0.3 bar)

Bowl pressure required to open drain: Less than 3 psig (0.2 bar)

Minimum air flow required to close drain: 0.2 scfm (0.1 dm³/s)

Manual operation: Depress pin inside drain outlet to drain bowl

Nominal bowl size

Short bowl: 1.9 fluid ounce (56 ml)

Long bowl: 2.2 fluid ounce (65 ml)

Materials

Body: Zinc

Bowl

Transparent: Polycarbonate

Guard for transparent bowl: Zinc

Metal: Zinc

Metal bowl liquid level indicator lens: Transparent nylon

Element: Synthetic fiber and polyurethane foam

Elastomers: Neoprene and nitrile

Service life indicator

Body: transparent nylon.

Internal parts: acetal.

Spring: stainless steel.

Elastomers nitrile

All Dimensions in Inches (mm)

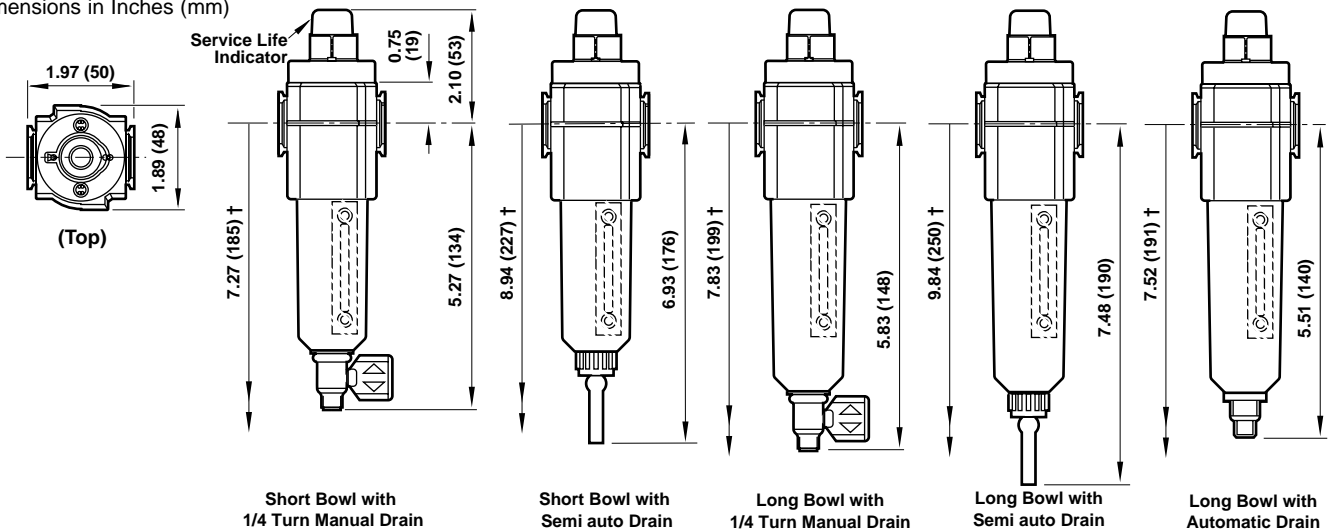

† Minimum clearance required to remove bowl.

Typical Performance Characteristics

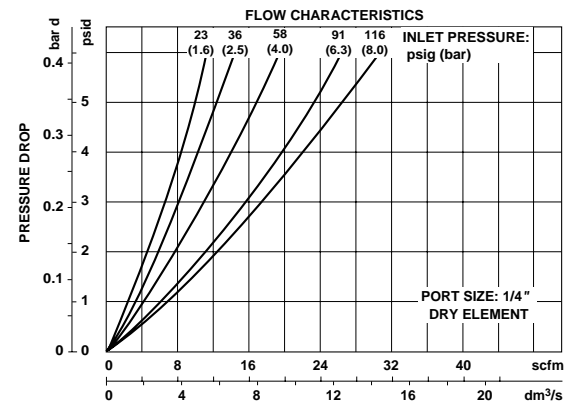
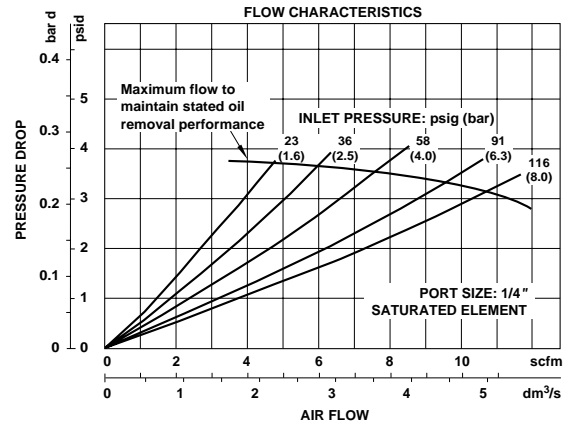

Service Kits

Item	Type	Part Number
Service kit	Seal and gasket	4380-500
Element	Coalescing	5925-09
Liquid level lens kit	Prismatic	4380-030
Replacement drains	1/4 turn manual	619-50
	Semi automatic	5379-RK
	Automatic	4000-50R

Service kit includes bowl o-rings.

**Excelon 73C Oil Removal Filter
(Coalescing) 1/4", 3/8", and 1/2" Port Sizes**

- Excelon design allows in-line or modular installation
- Quick release bayonet bowl
- Highly visible, prismatic liquid level indicator lens
- Standard mechanical service indicator turns from green to red when the filter element needs to be replaced
- Optional electrical service indicator provides electrical output when the filter element needs to be replaced
- Modular installations with Excelon 72, 73, and 74 series can be made to suit particular applications

Install an F73G pre-filter with a 5 µm filter element upstream of the F73C filter for optimum coalescing element life.



Ordering Information. Models listed include PTF threads, service indicator, automatic drain, and a metal bowl with liquid level indicator.

Port Size	Model	Flow† scfm (dm ³ /s)	Weight lb (kg)
1/4"	F73C-2AD-AD0	21.2 (10.0)	1.2 (0.54)
3/8"	F73C-3AD-AD0	21.2 (10.0)	1.2 (0.54)
1/2"	F73C-4AD-AD0	21.2 (10.0)	1.2 (0.54)

† Maximum flow with 90 psig (6.3 bar) inlet pressure to maintain stated oil removal performance.

Alternative Models

F 7 3 C - ★ ★ ★ - ★ ★ ★

Port Size	Substitute
1/4"	2
3/8"	3
1/2"	4

Threads	Substitute
PTF	A
ISO Rc taper	B
ISO G parallel	G

Service Indicator	Substitute
With electrical service indicator	E
With mechanical service indicator	D
Without	N

Element	Substitute
Coalescing	0

Bowl	Substitute
Metal with liquid level indicator	D
Transparent with guard	P
Transparent	T

Drain	Substitute
Automatic	A
Manual, 1/4 turn	Q

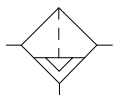
ISO Symbols

Automatic and Semi Automatic Drain

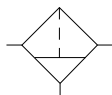

Manual Drain

See Section ALE-25 for Accessories



Technical Data

Fluid: Compressed air

Maximum pressure

Transparent bowl: 150 psig (10 bar)

Metal bowl: 250 psig (17 bar)

Operating temperature*

Transparent bowl: -30° to 125°F (-34° to 50°C)

Metal bowl: -30° to 150°F (-34° to 65°C)

* Air supply must be dry enough to avoid ice formation at temperatures below 35°F (2°C).

Particle removal: Down to 0.01 µm

Air quality: Within ISO 8573-1, Class 1 (particulates) and Class 2 (oil content)

Maximum remaining oil content in outlet air: 0.01 ppm at 70°F (20°C) with an inlet concentration of 17 ppm

Maximum flow at 90 psig (6.3 bar) inlet pressure to maintain stated oil removal performance: 21.2 scfm (10 dm³/s)

Manual drain connection: Will fit 1/8-27 and 1/8-28 pipe thread.

Automatic drain connection: Will fit 1/8-27 and 1/8-28 pipe thread. - Flexible tube with 3/16" (5mm) minimum I.D. can be connected to the automatic drain. Drain may fail to operate if the tube I.D. is less than 3/16" (5mm). Avoid restrictions in the tube.

Automatic drain operating conditions (float operated)

Bowl pressure required to close drain: Greater than 5 psig (0.3 bar)

Bowl pressure required to open drain: Less than 3 psig (0.2 bar)

Minimum air flow required to close drain: 0.2 scfm (0.1 dm³/s)

Manual operation: Depress pin inside drain outlet to drain bowl

Nominal bowl size: 3.5 fluid ounce (0.1 liter)

Filter materials

Body: Aluminum

Bowl

Transparent: Polycarbonate

Transparent with guard: Polycarbonate, steel guard

Metal: Aluminum

Metal bowl liquid level indicator lens: Transparent nylon

Element: Synthetic fiber and polyurethane foam

Elastomers: Neoprene and nitrile

Mechanical service indicator materials

Body: Transparent nylon

Internal parts: Acetal

Spring: Stainless steel

Elastomers: Nitrile

Typical Performance Characteristics

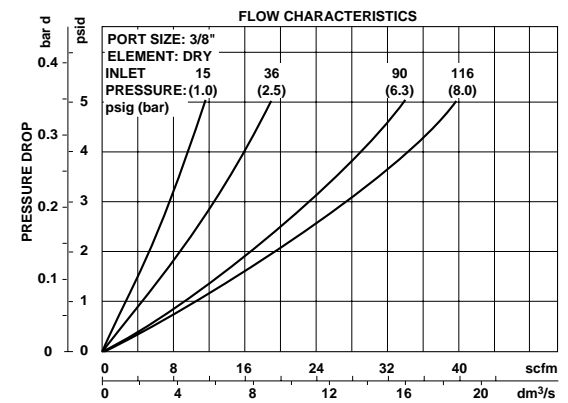
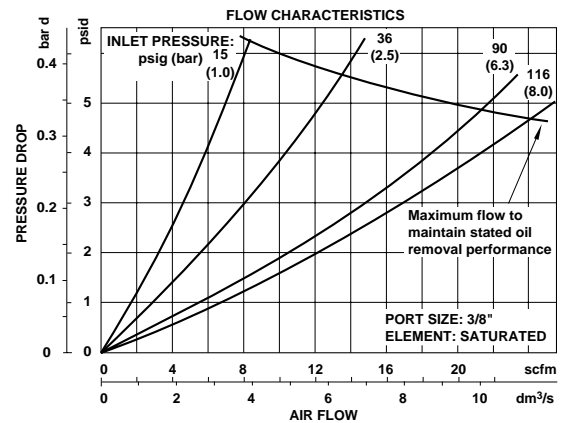

Service Kits

Item	Type	Part Number
Service kit	Seal & Gasket	4380-602
Replacement elements	Coalescing	4444-01
Liquid level lens kit	Prismatic	4380-020
Replacement drains	Automatic	4000-51R
	Manual quarter turn	619-50

Service kit includes element o-ring, automatic drain seal and bowl o-ring.

All Dimensions in Inches (mm)

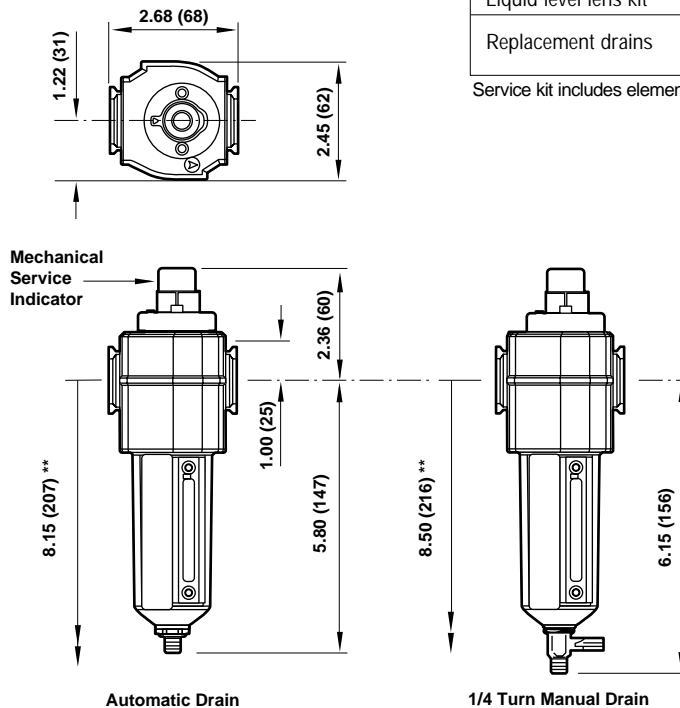

** Minimum clearance required to remove bowl.

**Excelon 74 Oil Removal Filters
(Coalescing) 3/8", 1/2", and 3/4" Port Sizes**

- Excelon design allows in-line or modular installation
- Quick release bayonet bowl
- Highly visible, prismatic liquid level indicator lens
- Standard visual service indicator turns from green to red when the filter element needs to be replaced
- Optional electrical service indicator provides electrical output when the filter element needs to be replaced
- Modular installations with Excelon 72, 73, and 74 series can be made to suit particular applications

Install an F74G pre-filter with a 5 µm filter element upstream of the F74C and F74H filters for optimum coalescing element life.



Ordering Information. Models listed include PTF threads, service indicator, automatic drain, and a metal bowl with liquid level indicator.

Main Port Size	Body and Element	Model Number	Maximum Flow* scfm (dm ³ /s)	Weight lb (kg)
3/8"	Standard	F74C-3AD-AD0	33.9 (16.0)	1.88 (0.85)
1/2"	Standard	F74C-4AD-AD0	33.9 (16.0)	1.84 (0.83)
1/2"	High Flow	F74H-4AD-AD0	59.3 (28.0)	2.45 (1.11)
3/4"	High Flow	F74H-6AD-AD0	59.3 (28.0)	2.40 (1.10)

* Maximum flow with 90 psig (6.3 bar) inlet pressure to maintain stated oil removal performance.

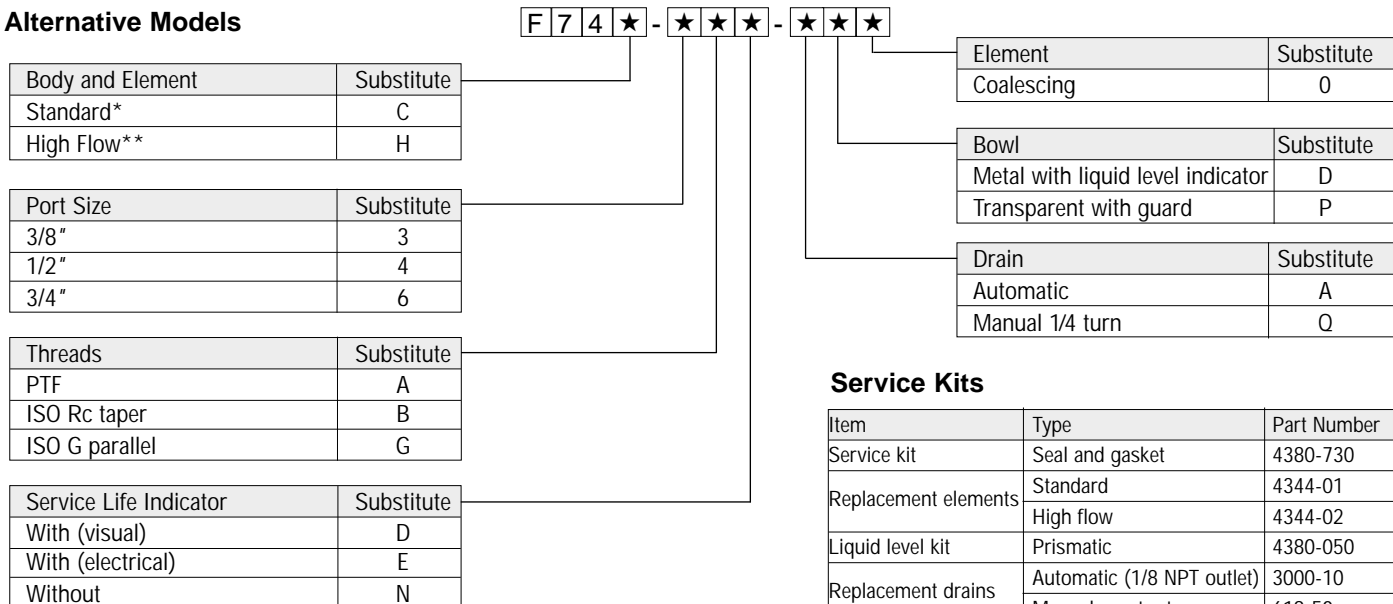
Alternative Models

* available with 3/8" or 1/2" ports
** available with 1/2" or 3/4" ports

Service Kits

Item	Type	Part Number
Service kit	Seal and gasket	4380-730
Replacement elements	Standard	4344-01
	High flow	4344-02
Liquid level kit	Prismatic	4380-050
Replacement drains	Automatic (1/8 NPT outlet)	3000-10
	Manual quarter turn	619-50

Service kits include element seal, bowl seal and drain seal.

See Section ALE-25 for Accessories



Technical Data

Fluid: Compressed air

Maximum pressure

Transparent bowl: 150 psig (10 bar)

Metal bowl: 250 psig (17 bar)

Operating temperature*

Transparent bowl: -30° to 125°F (-34° to 50°C)

Metal bowl: -30° to 150°F (-34° to 65°C)

* Air supply must be dry enough to avoid ice formation at temperatures below 35°F (2°C).

Particle removal: Down to 0.01 μm

Air quality: Within ISO 8573-1, Class 1 (particulates) and Class 2 (oil content)

Maximum remaining oil content in outlet air: 0.01 ppm at 70°F (20°C) with an inlet concentration of 17 ppm

Maximum flow at 90 psig (6.3 bar) inlet pressure to maintain stated oil removal performance

F74C: 33.9 scfm (16 dm³/s)

F74H: 59.3 scfm (28 dm³/s)

Manual drain connection: Will fit 1/8-27 and 1/8-28 pipe thread.

Automatic drain connection: Will fit 1/8-27 and 1/8-28 pipe thread. - Flexible tube with 3/16" (5mm) minimum I.D. can be connected to the automatic drain. Drain may fail to operate if the tube I.D. is less than 3/16" (5mm). Avoid restrictions in the tube.

Automatic drain operating conditions (float operated)

Bowl pressure required to close drain: Greater than 5 psig (0.3 bar)

Bowl pressure required to open drain: Less than 3 psig (0.2 bar)

Minimum air flow required to close drain: 2 scfm (1 dm³/s)

Manual operation: Depress pin inside drain outlet to drain bowl

Nominal bowl size: 7 fluid ounce (0.2 liter)

Materials

Body: Aluminum

Bowl

Transparent: Polycarbonate with steel bowl guard

Metal: Aluminum

Metal bowl liquid level indicator lens: Transparent nylon

Element: Synthetic fiber and polyurethane foam

Elastomers: Neoprene and Nitrile

Service indicator

Body: Transparent nylon

All Dimensions in Inches (mm)

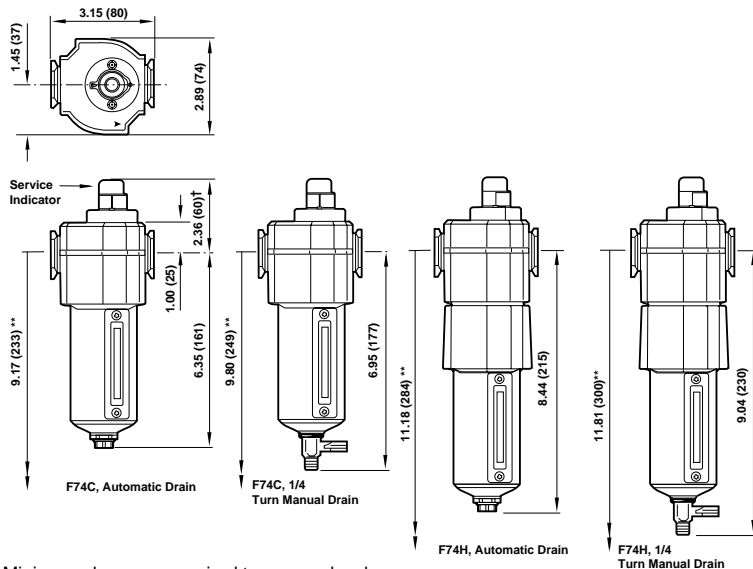

** Minimum clearance required to remove bowl.

† Dimension for alternative electrical service indicator is 1.98" (50.4 mm)

ISO Symbols

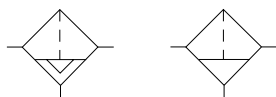

Automatic and Semi Automatic Drain

Manual Drain

Typical Performance Characteristics

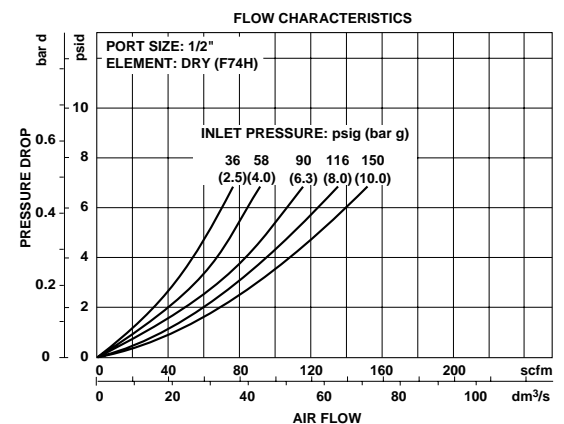
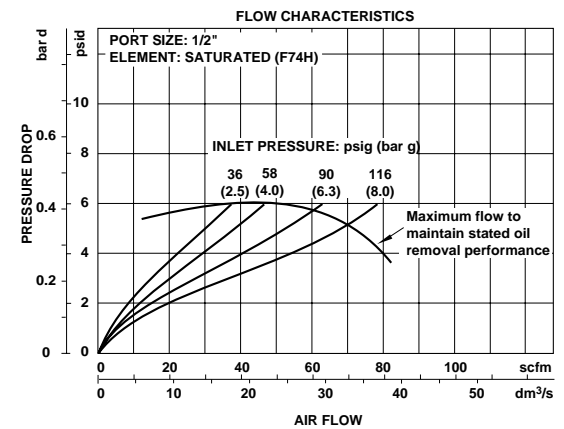
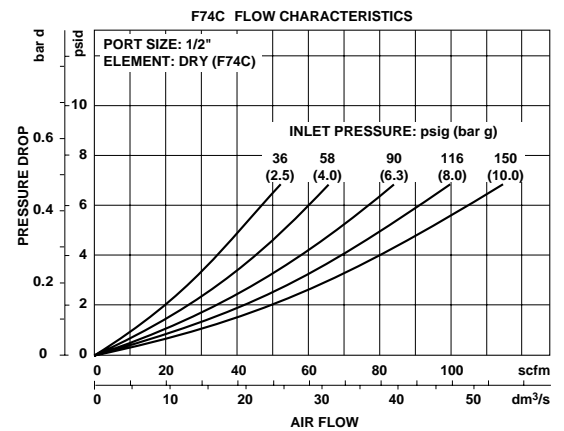
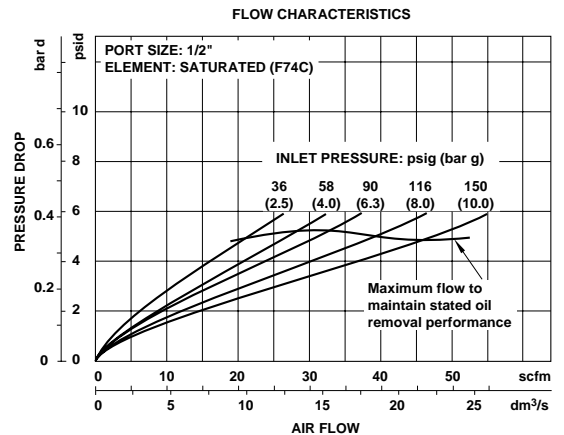

Olympian Plus Puraire High Efficiency Oil Removal Filter 1/4", 3/8", 1/2", and 3/4" Port Sizes

- Olympian Plus plug in design
- High efficiency oil and particle removal
- Quick release bayonet bowl
- High visibility prismatic sight glass
- Coalescing element service indicator

Install an F64G pre-filter with a 5 µm filter element upstream of the F64C filter for optimum coalescing element life.



Ordering Information. Models listed include PTF threads, service indicator, automatic drain, and metal bowl.

Drain Type	Port Size	F64C/H (only) Model	Maximum Flow* scfm (dm ³ /s)	Weight lb (kg)	With 5µm F64G Pre-filter Model	Weight lb (kg)
Automatic	1/4"	F64C-2AD-ADO	34 (16)	3.26 (1.48)	FFC64-208	5.45 (2.47)
	3/8"	F64H-3AD-ADO	60 (28)	3.75 (1.70)	FFC64-308	5.93 (2.69)
	1/2"	F64H-4AD-ADO	60 (28)	3.68 (1.67)	FFC64-408	5.86 (2.66)
	3/4"	F64H-6AD-ADO	60 (28)	4.43 (2.01)	FFC64-608	6.66 (3.02)

For replacement Filter (without yoke or pre-filter) substitute 'N' at the 5th and 6th digits eg: F64H-**NND**-ADO.

* Maximum flow with 90 psig (6.3 bar) inlet pressure to maintain stated oil removal performance.

Alternative Models

F 6 4 ★ - ★ ★ ★ - ★ ★ ★

Body type	Substitute
For 1/4"	C
For 3/8", 1/2", 3/4"	H

Port Size	Substitute
1/4"	2
3/8"	3
1/2"	4
3/4"	6

Threads	Substitute
PTF	A
ISO Rc taper	B
ISO G parallel	G

Element	Substitute
Coalescing	0

Bowl	Substitute
Metal with liquid level indicator	D
Transparent with guard	P

Drain	Substitute
Manual, 1/4 turn	Q
Auto drain	A

Service Life Indicator	Substitute
With (visual)	D
Without	N
With (electrical)†	E

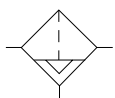
ISO Symbols

Automatic and Semi Automatic Drain

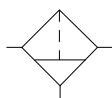

Manual Drain

See Section ALE-25 for Accessories



Technical Data

Fluid: Compressed air
 Maximum pressure: 250 psig (17 bar)
 Operating temperature*: 0° to +150°F (-20° to +65°C)

* Air supply must be dry enough to avoid ice formation at temperatures below +35°F (+2°C).
 Particle removal: 0.01 µm

Air quality: Within ISO 8573-1, Class 1 (particulates) and Class 2 (oil content).

Maximum remaining oil content: 0.01 mg/m³ at +70°F (+20°C) with an inlet concentration of 17 mg/m³.

Maximum flow at 90 psig (6.3 bar) inlet pressure to maintain stated oil removal performance:

1/2" ports: 74 scfm (35 dm³/s)

3/4" ports: 74 scfm (35 dm³/s)

1" ports: 127 scfm (60 dm³/s)

1/4 turn manual drain connection: 1/8" pipe thread

Automatic drain connection: 1/8" pipe thread

Automatic drain operating conditions (float operated):

Bowl pressure required to close drain: Greater than 5 psig (0.3 bar)

Bowl pressure required to open drain: Less than 3 psig (0.2 bar)

Minimum air flow required to close drain: 2 scfm (1 dm³/s)

Manual operation: Depress pin inside drain outlet to drain bowl

Nominal bowl size:

1 pint U.S. (0.5 liter)

1 quart U.S. (1 liter)

Materials:

Body: Aluminum

Yoke: Aluminum

Bowl: Aluminum

Liquid level indicator: Pyrex

Element: Synthetic fibre and polyurethane foam

Elastomers: Synthetic rubber

Service life indicator:

Body: Transparent nylon

Internal parts: Acetal

Spring: Stainless steel

Elastomers Nitrile

Typical Performance Characteristics

Inlet Pressure		Maximum Flow [†]			
		F64C		F64H	
psig	(bar)	scfm	(dm ³ /s)	scfm	(dm ³ /s)
15	(1)	14	(6.4)	24	(11.2)
45	(3)	23	(11.0)	41	(19.3)
70	(5)	30	(14.3)	53	(24.9)
90	(6.3)	34	(16.0)	59	(28.0)
100	(7)	36	(16.9)	63	(29.5)
130	(9)	40	(19.1)	71	(33.5)

[†] Maximum flow to maintain stated oil removal performance.

Service Kits

Item	Type	Part Number
Service kit	F64C/H	4380-200
Service kit (pre-filter)	F64G	4380-200
Element F64G (pre-filter)	5 µm	4338-01
Element F64C	Coalescing	4344-01
Element F64H	Coalescing	4344-02
Replacement sight glass	Prismatic (standard)	4380-040
	Pyrex	4380-041
Replacement drains	Automatic	3000-97
	Manual	684-84

Service kit includes port seals, louver o-ring, bowl o-ring and drain gasket.

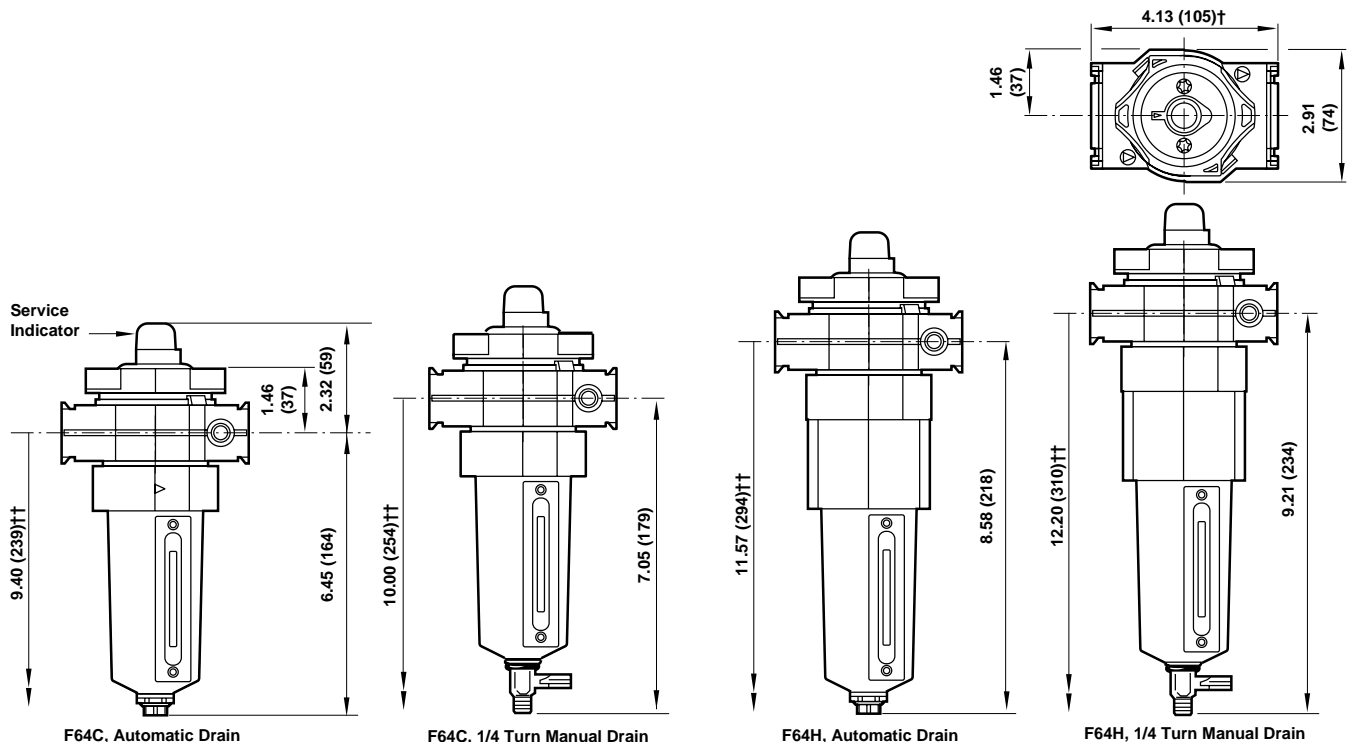

† 6.18" (157) for 3/4" ports.

†† Minimum clearance required to remove unit.

**68 Series Oil Removal (Coalescing) Filter
1/2", 3/4", and 1" Port Sizes**

- **Olympian Plus plug-in system**
- **Coalescing element provides high efficiency oil and particle removal**
- **Standard visual service indicator turns from green to red when the filter element needs to be replaced**
- **Oil and dirt contamination in outlet air within ISO 8573-1: Quality Class 1.7.2**
- **Factory optional electrical service life indicator provides electrical output when the filter element needs to be replaced - see page ALE-25-23**

Install an F68G pre-filter with a 5 µm filter element upstream of the F68C/H filter for optimum coalescing element life.



Ordering Information. Models listed include a yoke with PTF threads, filter with service life indicator, automatic drain, and bowl with liquid level indicator.

Port Size	Type	Model	Weight lb (kg)
1/2	Standard flow (short element)	F68C-4AD-AR0	5.19 (2.36)
3/4	High flow (long element)	F68H-6AD-AU0	5.85 (2.66)
1	High flow (long element)	F68H-8AD-AU0	5.72 (2.60)

Alternative Models

F 6 8 ★ - ★ ★ ★ - ★ ★ ★

Flow	Substitute
Standard, 1 pint (0.5 liter) bowl	C
High, 1 quart (1 liter) bowl	H

Port Size	Substitute
1/2"	4*
3/4"	6
1"	8
None	N

Threads	Substitute
PTF	A
ISO Rc taper	B
ISO G parallel	G
None	N

Service Life Indicator	Substitute
Visual	D
Electrical	E
Without	N

Element	Substitute
Coalescing	0

Bowl	Substitute
1 quart (1 liter) without liquid level indicator	C**
1 pint (0.5 liter) without liquid level indicator	M*
1 pint (0.5 liter) with liquid level indicator	R*
1 quart (1 liter) with liquid level indicator	U**

Drain	Substitute
Automatic	A
No drain (Closed bowl)	E
Manual	M
Manual, 1/4 turn	Q

* Only available with F68C.
** Only available with F68H.

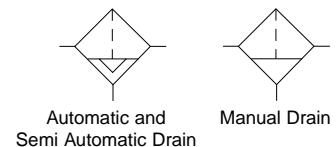
ISO Symbols



Technical Data

Fluid: Compressed air
 Maximum pressure: 250 psig (17 bar)
 Operating temperature*: 0° to +150°F (-20° to +65°C)

* Air supply must be dry enough to avoid ice formation at temperatures below +35°F (+2°C).

Particle removal: 0.01 µm
 Air quality: Within ISO 8573-1, Class 1 (particulates) and Class 2 (oil content).

Maximum remaining oil content: 0.01 mg/m³ at +70°F (+20°C) with an inlet concentration of 17 mg/m³.

Maximum flow at 90 psig (6.3 bar) inlet pressure to maintain stated oil removal performance:

1/2" ports: 74 scfm (35 dm³/s)

3/4" ports: 74 scfm (35 dm³/s)

1" ports: 127 scfm (60 dm³/s)

1/4 turn manual drain connection: 1/8" pipe thread

Automatic drain connection: 1/8" pipe thread

Automatic drain operating conditions (float operated):

Bowl pressure required to close drain: Greater than 5 psig (0.3 bar)

Bowl pressure required to open drain: Less than 3 psig (0.2 bar)

Minimum air flow required to close drain: 2 scfm (1 dm³/s)

Manual operation: Depress pin inside drain outlet to drain bowl

Nominal bowl size:

1 pint U.S. (0.5 liter)

1 quart U.S. (1 liter)

Materials:

Body: Aluminum

Yoke: Aluminum

Bowl: Aluminum

Liquid level indicator: Pyrex

Element: Synthetic fibre and polyurethane foam

Elastomers: Synthetic rubber

Service life indicator:

Body: Transparent nylon

Internal parts: Acetal

Spring: Stainless steel

Elastomers Nitrile

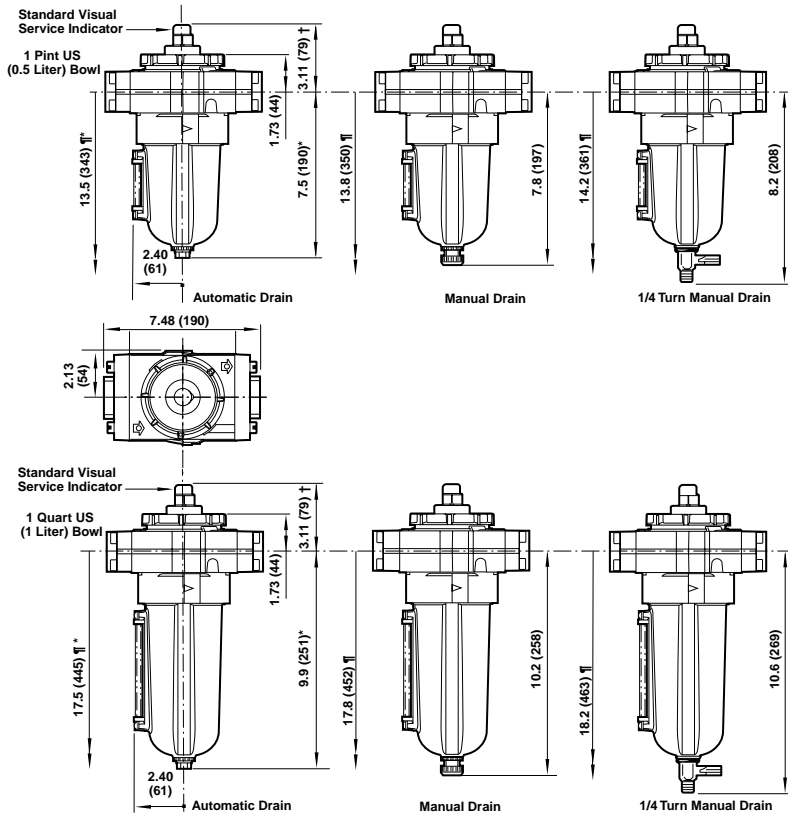

† For optional electrical service life indicator, add 0.02" (5 mm). * Dimension also applies to closed bottom bowl.
 † Minimum clearance required to remove bowl.

Typical Performance Characteristics

Inlet Pressure	Maximum Flow*					
	F68C 1/2" Ports		F68H 3/4" Ports		F68H 1" Ports	
psig (bar)	scfm	(dm ³ /s)	scfm	(dm ³ /s)	scfm	(dm ³ /s)
15 (1)	30 (14)	(14)	30 (14)	(14)	51 (24)	(24)
45 (3)	51 (24)	(24)	51 (24)	(24)	87 (41)	(41)
70 (5)	66 (31)	(31)	66 (31)	(31)	112 (53)	(53)
90 (6.3)	74 (35)	(35)	74 (35)	(35)	127 (60)	(60)
100 (7)	78 (36.7)	(36.7)	78 (36.7)	(36.7)	133 (63)	(63)
130 (9)	89 (42)	(42)	89 (42)	(42)	153 (72)	(72)

* Maximum flow to maintain stated oil removal performance.

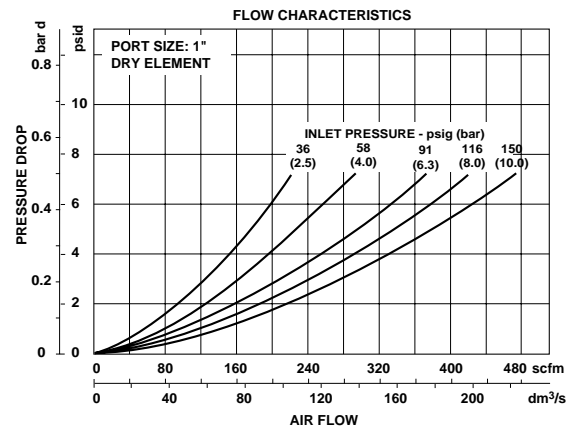
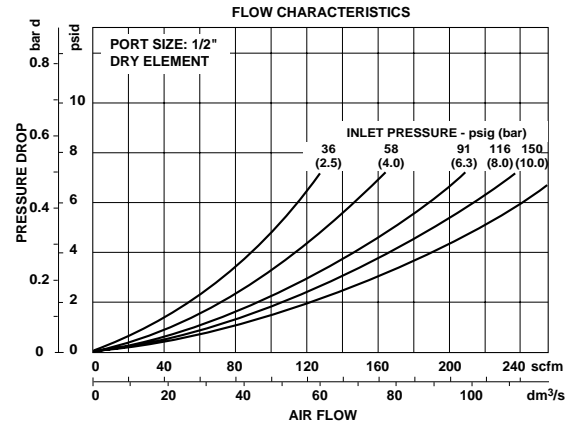

Service Kits

Item	Type	Part Number
Service Kit	Seal and gasket	4380-301
Replacement Elements	Standard flow (F68C)	5351-08
	High flow (F68H)	5351-03
Replacement	1 pint US (0.5 liter)	4380-060
Replacement	1 quart US (1 liter)	4380-061
Replacement Drains	Automatic (G 1/8 outlet)	3000-04
	Automatic (1/8 NPT outlet)	3000-03
	Manual	684-84
	Manual, 1/4 turn	619-50

Service kit Includes element seal, bowl seal, drain seal.

**F46 Oil Removal (Coalescing)
Filter 3/4", 1", and 1-1/4" Port Sizes**

- High efficiency oil and particle removal
- Screw-on bowl reduces maintenance time
- Can be disassembled without the use of tools or removal from the air line
- Standard service indicator turns from green to red when the filter element needs to be replaced

NOTE: Install an F17 filter with a 5 µm filter element upstream of the F46 filter for maximum service life.



Ordering Information. Models listed include service indicator, automatic drain, metal bowl with sight glass, and PTF threads.

Port Size	Model Numbers	Maximum Flow* scfm (dm ³ /s)	Weight lbs (kg)
3/4"	F46-601-A0DA	90 (42)	4.11 (1.86)
1"	F46-801-A0DA	125 (59)	4.05 (1.84)
1-1/4"	F46-A01-A0DA	125 (59)	4.29 (1.95)

* Maximum flow for oil-saturated element at 90 psig (6.3 bar) inlet pressure to maintain stated oil removal performance.

Alternative Models

F 4 6 - ★ ★ ★ - ★ ★ ★ ★

Port Size	Substitute
3/4"	6
1"	8
1-1/4"	A

Option	Substitute
Not applicable	0

Service Life Indicator	Substitute
Without	0
With (visual)	1
With (electrical)	4

Threads	Substitute
PTF	A
ISO Rc taper	B
ISO G parallel	G

Bowl	Substitute
Metal with sight glass	D
Metal	M

Element	Substitute
Coalescing	0

Drain	Substitute
Automatic	A
Manual	M

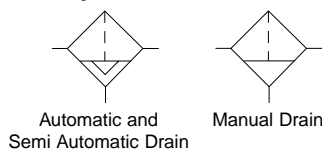
ISO Symbols

See Section ALE-25 for Accessories



Technical Data

Fluid: Compressed air
 Maximum pressure: 250 psig (17 bar)
 Operating temperature: * -30° to 150°F (-34° to 65°C)
 * Air supply must be dry enough to avoid ice formation at temperatures below 35°F (2°C)
 Particle removal: Down to 0.01 µm
 Air quality: Within ISO 8573-1, Class 1 (particulates) and Class 2 (oil content)
 Maximum remaining oil content in outlet air: 0.01ppm at 70°F (20°C) with an inlet oil concentration of 17 ppm.
 Maximum flow at 90 psig (6.3 bar) inlet pressure to maintain stated oil removal performance:
 3/4" ports: 90 scfm (42 dm³/s)
 1" ports: 125 scfm (59 dm³/s)
 1-1/4" ports: 125 scfm (59 dm³/s)
 Nominal bowl size: 1 quart US (1 liter)
 Manual drain connection: Will fit 1/8-27 and 1/8-28 pipe thread.
 Automatic drain connection: Will fit 1/8-27 and 1/8-28 pipe thread. - Flexible tube with 3/16" (5mm) minimum I.D. can be connected to the automatic drain. Drain may fail to operate if the tube I.D. is less than 3/16" (5mm). Avoid restrictions in the tube.
 Automatic drain operating conditions (float operated)
 Bowl pressure required to close drain: Greater than 5 psig (0.3 bar)
 Bowl pressure required to open drain: Less than 3 psig (0.2 bar)
 Minimum air flow required to close drain: 2 scfm (1 dm³/s)
 Manual operation: Depress pin inside drain outlet to drain bowl
Materials
 Body: Aluminum
 Bowl: Aluminum
 Bowl sight glass: Pyrex
 Elastomers: Neoprene and nitrile
 Filter element: Synthetic fiber and polyurethane foam

Typical Performance Characteristic

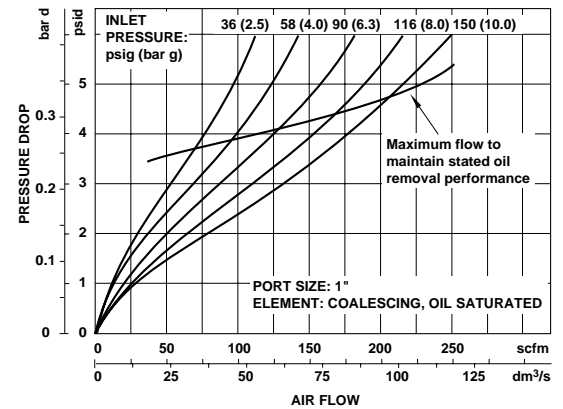
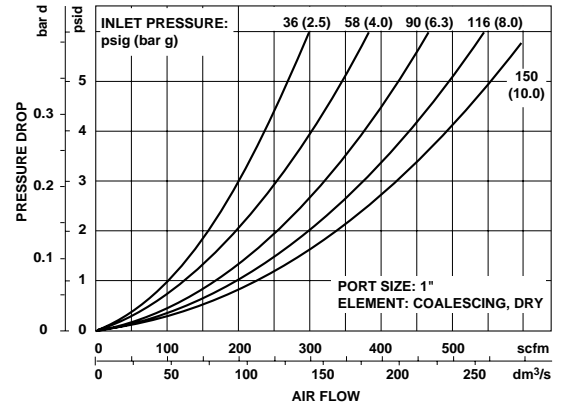

All Dimensions in Inches (mm)

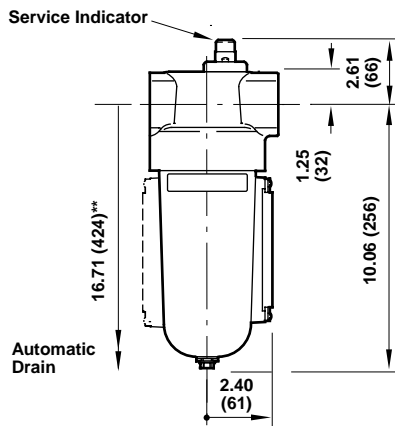
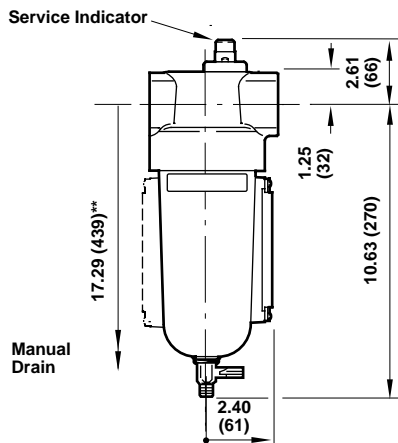
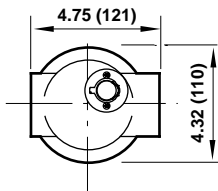

** Minimum clearance required to remove bowl.

Service Kits

Item	Type	Part number
Service kit	O-ring & gaskets	5351-04
Replacement drains	Automatic (1/8 NPT outlet)	3000-18
	Manual (1/4 Turn)	619-50

Service kit contains coalescing element, element o-ring, bowl o-ring, and drain gasket.

**18 Series Oil Removal Filter
(Coalescing) 1-1/2" and 2" Port Sizes**

- High efficiency oil and particle removal
- Highly visible, prismatic liquid level indicator lens
- Patented quarter turn manual drain
- Can be disassembled without removal from the air line
- Standard service indicator turns from green to red when the filter element needs to be replaced
- Optional electrical service indicator also available



Ordering Information. Models listed include service indicator, automatic drain, metal bowl with sight glass, and PTF threads.

Port Size	Body and Element	Model Numbers	Flow scfm (dm ³ /s)*	Weight lbs (kg)
1-1/2"	Standard	F47-B01-A0DA	250 (118)	15.51 (7.04)
2"	Standard	F47-C01-A0DA	300 (142)	14.26 (6.47)
2"	High Flow	F47-C21-A0DA	600 (283)	22.17 (10.06)

* Maximum flow at 90 psig (6.3 bar) inlet pressure to maintain stated oil removal performance.

Alternative Models

F 4 7 - ★ ★ ★ - ★ ★ ★ ★

Port Size	Substitute
1-1/2"	B
2"	C

Option	Substitute
Standard body and element	0
High flow body and element (use only with 2" ports)	2

Service Indicator	Substitute
Without	0
With (visual)	1
With (electrical)	4

Threads	Substitute
PTF	A
ISO Rc taper	B
ISO G parallel	G

Bowl	Substitute
Metal with sight glass	D
Metal	M

Element	Substitute
Coalescing	0

Drain	Substitute
Automatic	A
Manual, 1/4 turn	M

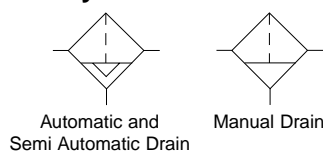
ISO Symbols

See Section ALE-25 for Accessories



Technical Data

Fluid: Compressed air
 Maximum pressure: 250 psig (17 bar)
 Operating temperature: * -30° to 150°F (-34° to 65°C)
 * Air supply must be dry enough to avoid ice formation at temperatures below 35°F (2°C).
 Particle removal: Down to 0.01 µm
 Air quality: Within ISO 8573-1, Class 1 (particulates) and Class 2 (oil content)
 Maximum remaining oil content in outlet air: 0.01 ppm at 70°F (20°C) with an inlet concentration of 17 ppm
 Maximum flow for oil-saturated element at 90 psig (6.3 bar) inlet pressure to maintain stated oil removal performance
 1-1/2" Ports: 250 scfm (118 dm³/s)
 2" Ports: 300 scfm (142 dm³/s)
 2" Ports, high flow element: 600 scfm (283 dm³/s)
 Typical flow for dry element at 90 psig (6.3 bar) inlet pressure and 5 psid (0.3 bar) pressure drop
 1-1/2" Ports: 780 scfm (368 dm³/s)
 2" Ports: 830 scfm (392 dm³/s)
 2" Ports, high flow element: 2300 scfm (1086 dm³/s)
 Nominal bowl size: 7 fluid ounce (0.2 liter)
 Manual drain connection: Will fit 1/8-27 and 1/8-28 pipe thread.
 Automatic drain connection: Will fit 1/8-27 and 1/8-28 pipe thread. - Flexible tube with 3/16" (5mm) minimum I.D. can be connected to the automatic drain. Drain may fail to operate if the tube I.D. is less than 3/16" (5mm). Avoid restrictions in the tube.
 Automatic drain operating conditions (float operated)
 Bowl pressure required to close drain: Greater than 5 psig (0.3 bar)
 Bowl pressure required to open drain: Less than 3 psig (0.2 bar)
 Minimum air flow required to close drain: 2 scfm (1 dm³/s)
 Manual operation: Depress pin inside drain outlet to drain bowl

Materials

Body, intermediate body, bowl: Aluminum
 Metal bowl liquid level indicator lens: Transparent nylon
 Filter element: Synthetic fiber and polyurethane foam
 Elastomers: Neoprene and nitrile
 Service indicator
 Body: Transparent nylon
 Internal parts: Acetal
 Spring: Stainless steel
 Elastomers: Nitrile

Typical Performance Characteristics

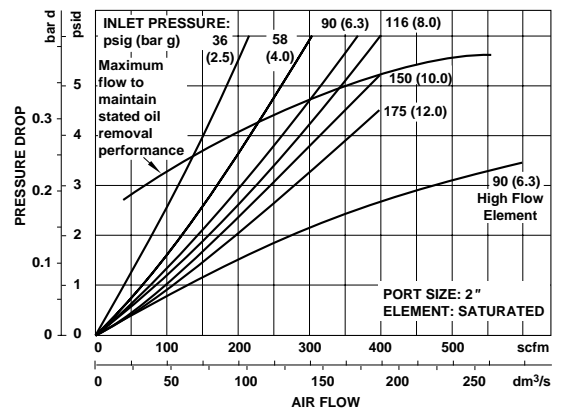
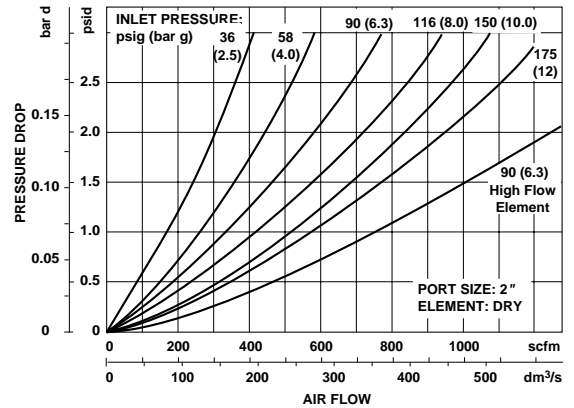

All Dimensions in Inches (mm)

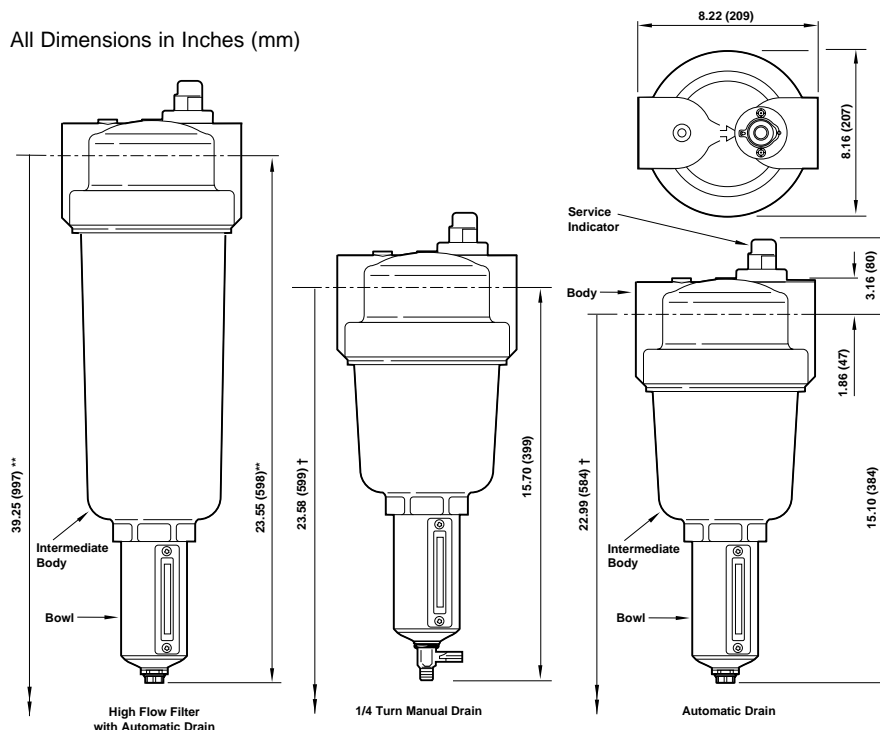

** Minimum clearance required to remove intermediate body and bowl. Add 0.59" (15 mm) for 1/4 turn manual drain.

† Minimum clearance required to remove intermediate body and bowl.